

FM 7-30

WAR DEPARTMENT FIELD MANUAL

SUPPLY AND EVACUATION THE INFANTRY REGIMENT; SERVICE COMPANY AND MEDICAL DETACHMENT

REGRADED UNCLASSIFIED BY
AUTHORITY OF DOD DIR. 5200.1 R
BY PAW/S ON 092J03

PROHIBITED. DISSEMINATION OF RESTRICTED MATTER. The information contained in restricted documents and the essential characteristics of restricted material may be given to any person known to be in the service of the United States and to persons of undoubted loyalty and discretion who are cooperating in Government work, but will not be communicated to the public or to the press except by authorized military public relations agencies. (See also par. 23b, AR 380-5, 15 Mar 44.)

UNCLASSIFIED

WAR DEPARTMENT

• 1 JUNE 1944

WAR DEPARTMENT FIELD MANUAL
FM 7-30

This manual supersedes FM 7-30, Infantry Field Manual, Service Company and Medical Detachment (Supply and Evacuation) Infantry Regiment, 31 December 1942.

INFANTRY
SUPPLY AND
EVACUATION

THE INFANTRY REGIMENT;
SERVICE COMPANY AND
MEDICAL DETACHMENT



WAR DEPARTMENT

1 JUNE 1944

RESTRICTED DISSEMINATION OF RESTRICTED MATTER. The information contained in restricted documents and the essential characteristics of restricted material may be given to any person known to be in the service of the United States and to persons of undoubted loyalty and discretion who are cooperating in Government work, but will not be communicated to the public or to the press except by authorized military public relations agencies. (See also par. 23b, AR 380-5, 15 Mar 44.)

United States Government Printing Office
Washington: 1944

WAR DEPARTMENT,
Washington 25, D. C., 1 June 1944.

FM 7-30, Infantry Field Manual, Supply and Evacuation, The Infantry Regiment; Service Company and Medical Detachment, is published for the information and guidance of all concerned.

[A.G. 300.7 (30 Apr 44).]

By order of the Secretary of War:

G. C. MARSHALL,
Chief of Staff.

OFFICIAL:

J. A. ULIO,
Major General,
The Adjutant General.

DISTRIBUTION:

As prescribed in paragraph 9a, FM 21-6, except Inf Sch (8,000); R 7 (5); Bn 7, 18 (3); C 7, 18 (2); IC 7 (15).

IC: T/O & E 7-13, Sv Co, Inf Regt; 7-29, Sv Co, Armd Inf Bn; 7-33, Inf Sv Co, Regt, Prcht; 7-53, Sv Co, Gli Inf Regt; 7-72, Hq & Hq & Sv Co, Lt Inf Regt; 7-86, Hq & Hq Co, Ranger Inf Bn; 7-96, Hq & Hq & Sv Co, Inf Bn Sep; 7-126, Hq & Hq & Sv Co, Inf Bn, Sep; 7-133, Sv Co, Mt Inf Regt.

For explanation of symbols see FM 21-6.

CONTENTS

	<i>Paragraphs</i>	<i>Page</i>
PART ONE. Supply and evacuation.		
CHAPTER 1. General	1-6	1
CHAPTER 2. Procurement and distribution of supplies.		
<i>Section I.</i> Class I supply	7-11	14
<i>II.</i> Class II supply.....	12-14	30
<i>III.</i> Class III supply.....	15-17	33
<i>IV.</i> Class IV supply.....	18-20	36
<i>V.</i> Class V supply.....	21-30	38
CHAPTER 3. Maintenance, repair, and other activities	31-34	56
CHAPTER 4. Medical service and evacuation	35-46	68
CHAPTER 5. Administrative plans and orders	47-48	83
PART TWO. Regimental service com- pany and medical detachment.		
CHAPTER 6. Regimental service company.		
<i>Section I.</i> Organization of the service company	49-53	90
<i>II.</i> Operation of the service company	54-57	108
CHAPTER 7. Organization of the regimen- tal medical detachment	58-63	119
<i>Appendix I.</i> List of references		130
<i>II.</i> Form for break-down of rations		132
<i>III.</i> Motor maintenance—echelons of maintenance		134

Part One

SUPPLY AND EVACUATION

Chapter 1

GENERAL

1. **REFERENCES.** a. For fundamentals of administration, see FM 100-10. For logistical data, see FM 101-10. For administrative orders, see FM 101-5.

b. Attention is directed to FM 21-7 for details as to how appropriate training films and film strips are intended to be used and how they are made available for use during training.

c. For military terms not defined in this manual or in FM 100-10, see TM 20-205.

2. **DEFINITIONS.** The following definitions supplement those contained in FM 100-10:

a. Administrative orders. Orders that cover supply, evacuation, and other administrative details of operations. Administrative orders are issued under circumstances where the instructions regarding these matters are too voluminous to be embodied in paragraph 4 of the field order, or when a field order is not being published and at the same time it is necessary to publish administrative instructions to the command. Division administrative orders are usually issued in written form. Regimental administrative orders may be oral or dictated, and in either complete or fragmentary form.

b. Collecting station. A division medical installation where sick and wounded are assembled from aid stations, sorted, treated if necessary, and evacuated to the division clearing station.

c. Point of release (Release point). A point along the route, either to the front or to the rear, at which transportation is released from the control of one echelon to that of another, usually for supply or evacuation purposes. The release point should be a well-defined, easily recognized terrain feature near the divergence of routes to the various elements of a unit.

d. Requirements. Those computed supplies needed for the equipment, maintenance, and operation of a military force for a given period, and classified as individual, organizational, initial, replacement, and reserve.

3. BASIC PRINCIPLES AND PROCEDURE. a.

The supply mission. The regimental supply mission is to provide the individual and unit with sufficient supplies to initiate and sustain combat until replenishment from the rear can be effected; and to effect replenishment from the rear despite the developments of combat. The supply plan is a success only when this mission has been accomplished.

b. Principles of supply. The principles governing supply operation are designed to carry out the supply mission in the most expeditious and efficient manner. They are applicable under all conditions, but the degree of application of any one principle will vary with the situation. These principles are:

(1) Supply is a command responsibility. A commander may charge certain members of his staff and other administrative personnel with certain supply functions, but they act only in the name of and for the commander. The responsibility for insuring the proper supply of the unit is that of the commander alone. He is also responsible for the supply of attached elements.

(2) An inseparable alliance exists between tactics and supply. The supply plan must support the tactical plan. The most brilliantly conceived and executed tactical plan will fail unless supported by a sound supply plan.

(3) *Plans must have simplicity and continuity.* The simple plan is usually the best plan. Continuity of supply requires constant forward planning.

(4) Flexibility and mobility in supply operations are necessary to meet rapidly changing situations. Flexibility is attained by decentralization of operations, efficient administrative control, and careful selection of locations for installations. Mobility is promoted by judicious distribution of supplies laterally, and in depth, and by keeping supply vehicles loaded to the maximum extent practicable. However, the more the individual and unit are burdened with supplies the less mobile they become. Hence a compromise must be made in order to attain both reasonable certainty of supply (continuity) and necessary tactical mobility.

(5) The impetus of supply is from the rear toward the point of consumption. It is the function of each element in the supply chain to push supplies forward within reach of elements in front. However, each commander is responsible for making his requirements known to higher authority in sufficient time to permit furnishing these supplies by normal methods and for making necessary arrangements for drawing and distributing supplies allocated to him. The impetus, therefore, should come from the rear only so far as subordinate commanders cannot assist themselves.

(6) Adequate supplies must be provided without creating an immobilizing surplus. Allowances are held to the minimum deemed necessary to meet the tactical situation. The fluidity which is characteristic of modern operations has a tendency to separate units and individuals from supply sources. This fre-

quently requires units and individuals to be self-sustaining. Under these conditions, the regiment must anticipate its requirements and provide adequate reserves on individuals and vehicles. When necessary, higher authority will be requested to furnish additional transportation for this purpose.

(7) Combat elements must be relieved of administrative details to the greatest extent possible. Administrative personnel justify their existence only when this is accomplished. Routine requirements, such as rations, of subordinate units of the regiment are supplied automatically. (See FM 100-10.) Whenever practicable, their other requirements are anticipated by supply officers and procured without request from the companies or detachments concerned. This, however, in no way relieves the commander of his responsibility for seeing to the adequate supply of his unit. Preparation of supply forms and maintenance of supply records are accomplished by administrative personnel.

(8) Precautions must be taken to safeguard supplies and transportation. This demands full utilization of all personnel and weapons present in a supply installation in the defense of such installation. The maximum exploitation of passive methods of protection, such as organization of the terrain and dispersion of vehicles and camouflage, is also of vital importance to the security of the supplies and transportation.

c. General procedure. (1) **PRESCRIBED SUPPLIES.** Supplies to be carried by the regiment on individuals, company transport, and regimental trains are prescribed by Tables of Organization and Equipment and directives published by the War Department and theater of operations commanders.

(2) **ECHELONS OF SUPPLY.** The regimental supply service usually operates in three echelons during active operations: the regiment, the battalion, and the company. When the regiment is in garrison or camp, supply is usually direct from regiment to company; the battalion echelon as such is then inoperative but should function under the regimental S-4 for training purposes.

(3) **PROCUREMENT AND DISTRIBUTION.** The channels of supply, both for requisition and distribution, follow the channels of command during tactical operations. Regimental headquarters receives requisitions from battalions and companies; it consolidates and forwards them to the appropriate section of the division special staff, which in turn forwards the requisitions to the appropriate army supply service and makes arrangements for the regiments to draw the supplies at army supply point(s). Upon notification by division as to when and where the supplies are to be drawn, the regiment, using its organic transportation, procures and transports them to the regimental area for distribution to subordinate units. Battalion headquarters receives requests from companies and forwards them to the

regimental supply officer; it receives supplies from the regiment, and issues or makes them available to companies. Attached elements are supplied by the unit to which they are attached,

4. DUTIES OF OFFICERS IN REGIMENTAL SUPPLY ECHELON. a. Regimental supply officer (S-4). (1) The regimental supply officer coordinates and supervises the regimental supply service and is responsible to the regimental commander for its functioning in accordance with the orders of higher headquarters and the tactical plan of the regiment. His sphere of activity includes the entire regimental area. His duties require him to keep in close touch with S-3 and the tactical situation, with the service company, with subordinate commanders, with the division G-4, and with all supply establishments. While the supply office group is usually divided between the command post and the train bivouac, the supply officer keeps in touch with the regimental command post and personally goes wherever his presence is needed.

(2) In general, the regimental supply officer is charged with duties which pertain to the supply section of the regimental staff. (See FM 101-5.) Specifically, his duties relate to planning for and supervising matters concerning the following:

(a) Procurement, storage, transportation, and distribution of all supplies (coordination as necessary with S-3).

(b) Location of supply, medical, and maintenance installations (coordination with S-3).

(c) Maintenance of equipment.

(d) Salvage.

(e) Collection and disposal of captured supplies (coordination with S-2 for examination of materiel and with division G-4 for disposition).

(f) Construction, procurement, operation, and maintenance of facilities relating to supply, shelter, and transportation, exclusive of fortification materials.

(g) Evacuation of personnel.

(h) Evacuation of supplies in retrograde movements and arrangements for destruction of those supplies that would otherwise fall into the hands of the enemy (coordination with S-3).

(i) Traffic control (coordination with S-3).

(j) Recommendations as to protection of the regimental train bivouac and other rear supply installations (coordination with S-3).

(k) Supervision of property responsibility.

(l) Preparation of administrative plans in coordination with other staff officers as necessary, and dissemination of information by means of paragraph 4 of field orders as well as through fragmentary administrative orders.

b. Service company commander. The service company commander is the principal agent of the regi-

mental supply officer (S-4) in the execution of approved supply plans, except for ammunition, pyrotechnics, antitank mines, and chemical supply. (See pars. 50 and 54.) He commands the regimental train bivouac. (See par. 57.) He usually supervises the receipt and distribution of all supplies except class V items and medical supplies. The latter are sent direct from the division to the medical detachment. (See pars. 60a and 62b.)

c. Munitions officer. The munitions officer is assistant to the regimental supply officer. During combat, he commands sections of the regimental ammunition train while they are under regimental control. He also commands any company transport that may be employed under regimental control to obtain ammunition at supply points established by higher headquarters. He is charged with procuring ammunition and other class V items and distributing them to battalions and other combat units of the regiment in accordance with the approved plan and unit needs. He establishes and operates the regimental ammunition supply point. He prepares ammunition records and reports.

d. Regimental motor transport officer. The regimental motor transport officer employs elements of his platoon as directed by the service company commander to procure and distribute supplies and perform second echelon maintenance on regimental motor vehicles. (See par. 52.)

5. DUTIES OF OFFICERS IN BATTALION SUPPLY ECHELON. a. Battalion supply officer (S-4).

(1) The battalion supply officer is assigned to the transportation platoon, service company. (See par. 52.) He performs staff and supply duties as directed by the battalion commander and is responsible for the functioning of the battalion supply system in the field and in combat, with particular reference to rations, water, ammunition, gasoline, and oil.

(2) The duties of battalion S-4 include—

(a) Preparation of the battalion supply plan based upon the regimental supply plan and the tactical plan of the battalion commander.

(b) Supervision of elements of the company transport and battalion trains (ammunition and kitchen and baggage trains) when they are operating under battalion control. He is assisted in this duty by the battalion motor transport officer.

(c) Coordination with the regimental supply echelon regarding details relating to the movement of battalion supplies and trains.

(d) Determination of the supply requirements for companies and attached units through personal contact.

(e) Establishment and operation of the battalion ammunition supply point.

(f) Supervision, during combat, to insure that an adequate supply of ammunition is delivered to companies and any attached units.

(g) Reconnaissance for covered routes between the battalion and the regimental supply points and points of release of trains, and regulation of the movement of vehicles on these routes.

(h) Coordination of supply operations with the tactical situation, and the supply plans with the tactical plans of the battalion commander, by keeping in close touch with the battalion command post at all times.

b. Battalion motor transport officer. (1) The battalion motor transport officer is a member of the battalion headquarters company. His staff duties as motor transport officer constitute his principal functions.

(2) The duties of the battalion motor transport officer include—

(a) Assisting the battalion S-4 in the supervision of such company transport and elements of the regimental trains as may be grouped under battalion control.

(b) Supervision, coordination, and expedition of the movement of company transport and ammunition train vehicles between company areas and the battalion ammunition supply point so as to insure an adequate supply of ammunition to all companies.

(c) Supervision and coordination of first and second echelon motor maintenance activities within the battalion.

c. Ammunition and pioneer platoon leader. (1) The leader of the battalion ammunition and pioneer platoon performs such staff duties as the battalion commander may direct. He is charged with the supervision of his platoon in the execution of ammunition supply and pioneer tasks. He accomplishes simple field engineering (pioneer) tasks not requiring the technical and special equipment of engineer troops. He assigns duties to members of his platoon in accordance with the requirements of the situation after consultation with the battalion S-4. He is also the battalion gas officer and battalion munitions officer.

(2) His duties include—

(a) Pioneer reconnaissance; control of the pioneer operations of his platoon. (See FM 7-20.)

(b) Assistance to the battalion S-4 in selection, establishment, and operation of the battalion ammunition supply point. (See par. 23.)

(c) Use of his platoon to assist in hand-carry of ammunition to company areas when this is necessary.

(d) Supervision and coordination of gas defense training and measures within the battalion, including inspection of gas defense equipment and use of decontaminating agents.

6. RESPONSIBILITY AND DUTIES OF COMPANY COMMANDERS. The company is the basic unit with administrative functions. Each company commander is responsible for the administration of his company and its supply. This responsibility cannot be delegated. (See par. 3b(1).) The company commander is responsible for making timely requests for supplies and for distributing supplies received to the members of his company. He is also responsible for the supply of attached units or personnel. In combat, he controls the employment of company transportation within the company area, and insures the timely replenishment of ammunition to his platoons. He is assisted in these matters by his second-in-command and the company supply sergeant.

Chapter 2

PROCUREMENT AND DISTRIBUTION OF SUPPLIES

Section I.

CLASS I SUPPLY

7. GENERAL. a. Class I supplies are those articles which are consumed at an approximately uniform daily rate, irrespective of combat operations or terrain, and which do not necessitate special adaptation to meet individual requirements. Rations and water are the principal class I items for infantry. (See fig. 1.)

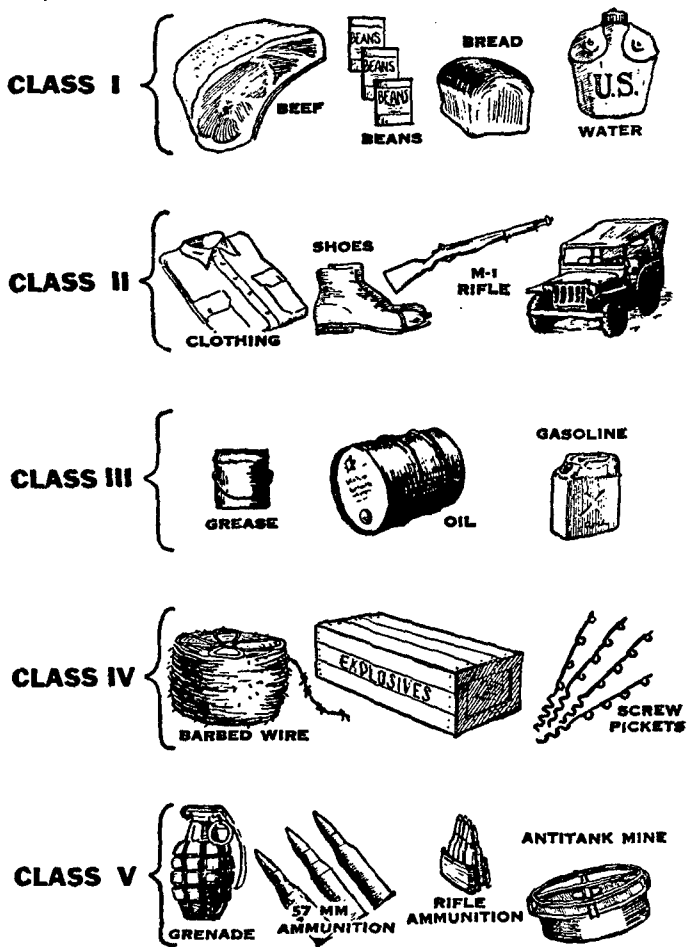

Figure 1. Classes of supply, type items.

b. A ration is the allowance of food for one person for one day. The garrison ration is ordinarily prescribed in time of peace. It is issued in the form of a money allowance. Units draw such available food components as they may elect within the limits of this allowance, and may be credited with ration savings. The field ration is ordinarily issued in time of war, national emergency, or field training. It is issued in kind and the ration savings privilege is suspended. Its components and substitutes are prescribed by the War Department or the commander of the field forces, and may consist of field ration A, B, C, D, K, or 10-in-1, or combinations of these.

(1) Field ration A corresponds in general to the peacetime garrison ration and generally is perishable. Being perishable, it is not suitable as a reserve ration.

(2) Field ration B is the same as field ration A except that nonperishable substitutes replace perishable items. This ration is suitable as a reserve ration.

(3) Field ration C is a cooked, balanced ration in cans. Each ration consists of three cans of prepared meats and vegetables and three cans of crackers, sugar, soluble coffee, and a confection. As this ration is not perishable, it is suitable for use as a unit reserve or individual reserve.

(4) Field ration D consists of three 4-ounce concentrated food bars, largely chocolate, three bars being one ration. It is a nonperishable ration and is suitable for use as an individual reserve.

(5) Field ration K is a concentrated, cooked ration composed of a breakfast, dinner, and supper unit. Each unit is packed in a paper box wrapped in paraffin paper. This ration is nonperishable and is suitable for use as an individual reserve.

(6) The 10-in-1 ration is a cooked ration packed in a fiber box inclosing two packages, each containing rations for five men. This ration is suitable for use as a reserve ration and for issue to patrols and small groups.

c. Prior to combat, one or more meals of field rations C, D, or K should be procured and issued to individuals as an individual reserve. Organizations or small detachments may be issued suitable field rations for independent missions when such units must be self-sustained for short periods. (See par. 3b(6).)

d. Troops should be provided with three meals daily; when practicable, two of these meals should be hot.

8. PROCUREMENT OF RATIONS. a. The quantity and type of rations to be carried by individuals and on unit trains as a prescribed load is announced from time to time by the division or higher commander. Rations are received and distributed daily by a relatively standard procedure. They are ordinarily obtained by the regiment during one 24-hour period for consumption during the next 24-hour period. In the combat zone, it is usually necessary

to draw rations in bulk, divide them into company lots, and distribute them as cooked meals, all under cover of darkness. Consumption of a given ration issue begins with either breakfast or supper, preferably supper. The 24-hour period in which it is planned that rations will be consumed is called a "ration cycle."

b. In combat, the daily strength report constitutes the requisition for rations. Companies and detachments transmit their strength reports through command channels to regimental headquarters. There the S-1 section makes a consolidated report and sends it to division headquarters; one copy is prepared for the regimental supply officer. This report is the basis on which rations in bulk are issued to the regiment at the army supply point (railhead) one or more days later. At the time of issue, the regimental supply officer or his representative makes adjustment with the railhead officer to meet any differences shown by the most recent strength report.

c. The army quartermaster service sorts rations at or near supply points into lots for regiments and smaller units. The regiment sends transportation to the army supply point to obtain the rations according to a time schedule established by the division. Rations are loaded by army service personnel assisted by truck drivers. Rations received are checked against itemized lists furnished at the time of issue.

9. DISTRIBUTION OF RATIONS. a. The regimental supply point is ordinarily established at the location of the kitchen and baggage train or other convenient place in the regimental train bivouac. (See par. 57.) The receiving and distributing group of the service company, assisted by such additional personnel as are available and required, unloads and sorts the rations at the regimental supply point. The amounts due each company are determined by multiplying the strength of each unit, including personnel attached for rations, by the prescribed allowance per man per item. (See app. II.) When these amounts are determined, the various items are weighed or counted and divided into company lots. This break-down, supervised by an officer, should be completed before beginning distribution in order to avoid confusion and to equalize overages or shortages. At least once each week, a field officer should check the methods used in determining amounts due and inspect the division of rations into company lots.

b. Details from company mess groups receive company lots at the regimental supply point and carry them to the kitchens. If the kitchen locations are beyond hand-carrying distance from the supply point, one or more kitchen trucks of a battalion section are used for delivery. (See fig. 2.)

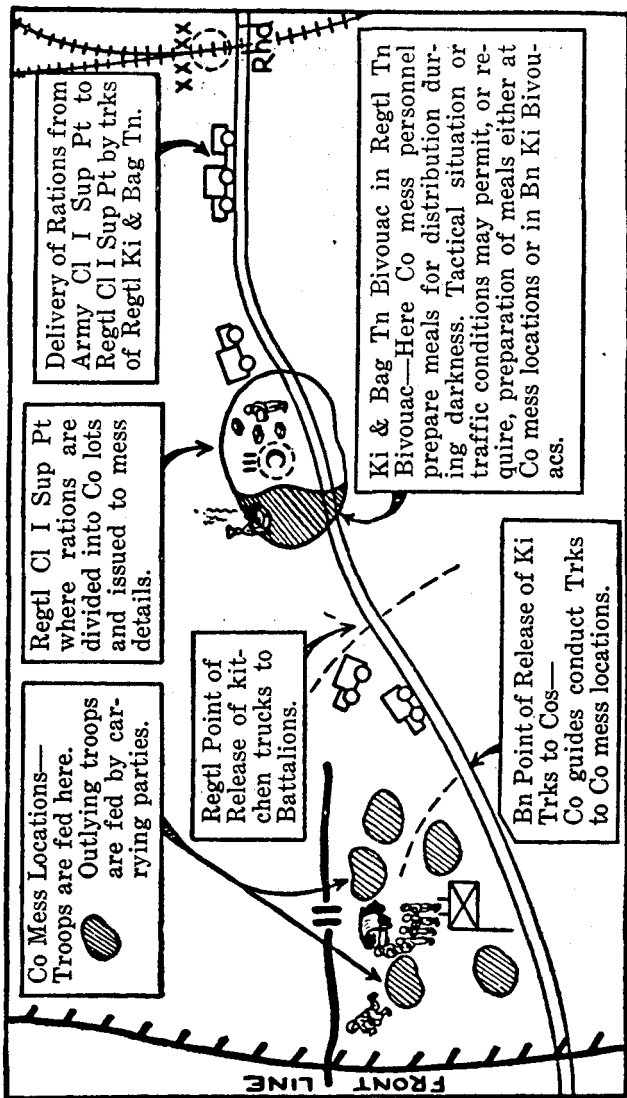

Figure 2. Ration distribution.

10. PREPARATION AND DELIVERY OF RATIONS TO TROOPS. a. Meals are prepared by each company mess detail on field ranges at—

(1) Kitchen locations in the regimental train bivouac.

(2) Battalion kitchen bivouacs located farther forward than the regimental train bivouac.

(3) The company mess location in the area occupied by the company.

b. (1) During combat, meals are usually prepared on field ranges (wood or gasoline) either entirely or in part at a rear kitchen location (usually in the regimental train bivouac; sometimes in battalion kitchen bivouacs). From there, meals are transported in food containers close to troop locations by kitchen trucks. One truck (with trailer, if necessary) may be used to deliver food to more than one company if a shortage of vehicles or tactical circumstances require; otherwise, one truck is used for each company. Since tactical considerations ordinarily preclude daylight movement of kitchen trucks into areas of forward companies, a hot supper is prepared and loaded on kitchen trucks by dark. At dark, the trucks are moved under regimental control (if they are going from the regimental train bivouac) to a regimental point of release from which they proceed under battalion control to a battalion point of release. From the battalion point of release they are led by company guides under company control to company mess locations where supper is

issued. If the trucks are to revert to regimental control after feeding of supper, they are conducted by company guides back to the battalion point of release; from this point they move under battalion control to the regimental point of release, where they come under regimental control. They then proceed to the regimental train bivouac area. (See fig. 2.)

(2) Infantry units are also provided with one-burner cooking outfits on the basis of one per 12 men. These are designed for use by patrols and small groups in preparation of meals when it is not practicable to provide hot food prepared at the kitchen locations.

c. The company mess location should afford concealment from hostile observation and should provide defilade from hostile fire. It should be as near the troops to be fed as tactical conditions permit. The company commander selects the company mess location, sends a guide to meet the kitchen truck at the battalion point of release, and upon its arrival sees that his troops and attached elements are fed. (Food containers are carried forward by carrying parties to troops who cannot come to the mess location. Arrangements are made by the company commander to have carrying parties at the mess location when the truck arrives. They are told the latest hour at which empty containers must be returned for use in delivering the next hot meal.)

d. Breakfast is usually issued as a hot meal and lunch as a cold meal. These meals are prepared at rear kitchen locations or at company mess locations, when practicable. The gasoline field range, unlike the wood-burning range, has a concealed, smokeless flame; therefore with proper camouflage discipline, it can be used in company mess locations with less danger of disclosure. Breakfast and lunch are prepared during the night and are issued at the latest hour of darkness that satisfies tactical requirements and permits return of containers and withdrawal of trucks into the train bivouac before daylight.

e. When a complete ration is on hand at dark, kitchen trucks may go forward from the bivouac and serve all three meals before returning. In this event, supper is prepared at the bivouac; breakfast and lunch are prepared at the company mess locations or at other convenient forward locations. This procedure requires only one round trip between the regimental train bivouac and company mess locations during the night and often may be advisable because of traffic conditions. However, this procedure entails greater difficulty for mess personnel and may be impracticable when units are in contact with the enemy.

f. When, for any reason, cooking in the forward area is impracticable, the following procedure may be used: At dark, kitchen trucks carry supper forward to company mess locations and, as soon as emptied food containers are reloaded, return to bivouac. While this is taking place, company mess

personnel at the bivouac begin preparation of the hot breakfast and cold lunch. Kitchen trucks then carry these two meals forward. This procedure involves two trips forward during the night and sometimes may be impracticable. When not required for normal functional operations, weapon carriers may be used to advantage for delivering food and water to troops.

g. When it is impracticable to effect the delivery of rations to troops in the usual manner, the individual reserve ration should be consumed, but only on instructions of battalion and separate company commanders; in isolated cases, blanket authority should be given for its use. When practicable, all or a portion of the reserve ration should be heated in order to provide maximum nourishment and stimulation.

h. The regimental supply officer determines the best plan for rationing the troops and, after approval by the regimental commander, transmits the plan to battalion supply officers and to commanders of separate companies and detachments. Details of the plan are transmitted to the service company commander as early as practicable in order that he may give timely instructions to mess personnel of the various companies. The ration plan includes such of the following instructions as are appropriate:

(1) Location of kitchen bivouac(s) (usually in regimental train bivouac).

(2) Place of preparation of each meal (regimental train bivouac, advanced regimental or battalion kitchen areas, or company mess locations).

(3) Number of kitchen and baggage vehicles per battalion to be employed for delivering food to troops (usually one truck per company; three per battalion when necessary to conserve transportation or reduce vehicular traffic).

(4) Detailed instructions relative to loading containers of food to serve elements of companies in remote locations.

(5) Additional items of supply that are to be sent forward to troops.

(6) Hour(s) kitchen trucks will leave bivouac for delivery of meal(s) to troops.

(7) Hours and places of release to battalions and of reversion to regimental control.

(8) Restrictions upon movement.

i. Upon receipt of instructions from the regimental supply officer, the battalion supply officer makes his plan. It includes additional supplies to be brought forward, how to move kitchen and baggage vehicles while under battalion control, and suitable point(s) of release to companies. (For delivery and collection of individual rolls, see par. 47h.) When his plan is approved by the battalion commander, the battalion supply officer advises each company concerned and arranges for company guides to meet and conduct trucks from the battalion

point of release to company mess locations. He arranges to have certain companies mess any troops in the battalion area who are without messing facilities or are widely separated from their companies. When the kitchens are under regimental control, he informs the regimental S-4 of the arrangements in time to insure that instructions are issued to the mess personnel, through the service company commander, for the appropriate loading of vehicles. He also makes certain that, upon release to the battalion, vehicles proceed properly to the battalion point of release. After completion of messing, he supervises the movement of vehicles from the time they are returned to battalion control until they pass to regimental control.

j. The foregoing procedure usually meets most tactical requirements, but is modified as necessary to meet special circumstances. Ration distribution must be kept flexible, and the regimental supply officer often must modify the normal procedure. The responsibility of each unit for distribution of rations and water begins when it receives notice from the next higher echelon of the time and place where supplies will be available, and ends when the supplies are released to the next lower echelon.

11. WATER SUPPLY. a. Average water requirements (see note 1) under varying conditions of service, expressed in gallons per man and vehicle per day, may be computed as follows:

WATER REQUIREMENTS TABLE
(gallons)

	In battle	March and bivouac	Temporary camp	Semi-permanent camp in rest area	Cantonment
Men	1½ to 2 ¹	2	5	30	50
Motor vehicles	1 to 2¼ ²	¼ to 1	¼ to 1	¼ to 30	¼ to 50

¹ See notes 2 and 3.

² See note 3.

NOTES

1. Modify according to circumstances, especially in hot climates. Maximum requirement may exceed the average by from 15 to 100 percent.
2. One-half gallon per man is the absolute minimum, for a period of not more than 3 days.
3. Battle experience indicates that 2½ gallons per man and 6 gallons per radiator should be provided in desert climates.
4. Organizations are supplied with 5-gallon cans for carrying water.

b. Filled water cans are carried by kitchen and baggage vehicles as part of their normal loads. Water is replenished locally wherever practicable. Water which has not been inspected and approved by a medical officer or an Engineer Corps water supply detachment will be chlorinated before being used for drinking and cooking purposes. When local sources are limited, division engineers will establish and operate one or more division water supply points, in the vicinity of the train bivouacs, at which water cans are refilled. When kitchen and baggage vehicles are under regimental control, the service company commander is responsible for refilling water cans at the designated supply point, in accordance with prescribed schedules. Filled cans are usually sent forward with meals. Canteens are refilled at company mess locations; this can be expedited, without waste, by emptying cans into water sterilizing bags having multiple outlets. Members of platoons fed by carrying parties refill their canteens from water containers brought to platoon mess locations or send their canteens to the company mess location to be refilled.

c. There are several expedients that may be adopted for the sterilization of water.

(1) Calcium hypochlorite is the agent normally used to sterilize water in the Lyster or water sterilizing bag. One ampule (0.5 gram) of this substance, the size normally used to sterilize 36 gallons in the water sterilizing bag, may be emptied into a canteen full of water. When the ampule is fully

dissolved and if the solution is used immediately, a quantity sufficient to fill the metal cap of his canteen may be dispensed to each soldier and will be adequate to sterilize the water in his canteen. Thirty minutes should elapse before the water is drunk.

(2) Individuals are issued water purifying (Halazone) tablets, to be used when they are separated from their unit source of supply.

(3) Boiling water for 3 to 5 minutes is a highly efficient method, but is impracticable for large groups and is frequently inadvisable for tactical reasons.

Section II.

CLASS II SUPPLY

12. GENERAL. a. Class II supplies comprise articles for which allowances are established by Tables of Equipment. Type items are clothing, gas masks, arms, trucks, radio sets, tools, instruments, and certain medical items. (See fig. 1.)

b. Clothing and both individual and organizational equipment are ordinarily replaced during periods when the regiment is not engaged in combat. They are generally obtained by requisition or exchange on the basis of actual or estimated requirements. Motor vehicles may be obtained by arrangements through division for direct exchange of unserviceable vehicles for serviceable vehicles from the army replacement pool. During combat, when weapons or prescribed items of individual or organizational equipment are required to replace those damaged, destroyed, or lost, companies send requests to the regimental supply officer, who has the consolidated requisition sent to the appropriate division supply service. This agency makes the necessary arrangements for the procurement of the items requested and notifies the regimental supply officer when and where to obtain them. When an allocation of supplies has been made, an informal request may be

made by the regimental supply officer and should be forwarded to the G-4 of the division or other headquarters controlling the credit. The staff supply officer concerned, at the direction of G-4, will then make the necessary arrangements with the army to provide the items requested. The service company commander is charged with receiving and distributing class II supplies, for which purpose he uses personnel of the receiving and distributing group and available vehicles and personnel of the transportation platoon. Delivery may be made directly to company details in the train bivouac, who arrange to have the items carried forward. For repair and replacement of equipment, see paragraph 33.

13. ENGINEER. Engineer entrenching equipment and the vehicle(s) for its transport constitute a part of the equipment issued to the ammunition and pioneer platoon of each battalion headquarters company. When the tactical situation requires, this equipment is made available to companies in accordance with the battalion commander's plan. The leader of the battalion ammunition and pioneer platoon will normally be charged with the actual distribution and the subsequent recovery of the entrenching equipment within the battalion.

14. MEDICAL. Supplies needed by the medical detachment may be procured by formal requisition, informal request, or exchange. Formal requisitions are forwarded to the division surgeon who makes

arrangements for procurement at the army medical supply point. Usually, the supplies are procured by the service company and distributed by it to the units concerned. The regimental section of the medical detachment normally takes charge of distribution within the medical detachment. During combat, the medical detachment usually obtains its requirements by informal request, the battalion and/or regimental surgeons calling on the division collecting company for replenishment. Resupply of some items of field equipment (litters, blankets, splints, etc.) is effected by exchange with the next higher medical echelon. (See par. 62.)

Section III.

CLASS III SUPPLY

15. GENERAL. a. Class III supplies for infantry units consist primarily of gasoline, lubricating oil, and grease. (See fig. 1.) The amount of these supplies consumed in the daily operation of the regiment varies within wide limits, depending on the distance the regiment moves, distance to army supply points, and quantity of supplies to be hauled. The estimated requirements of gasoline and oil for the regiment is reported to the division daily. For method of estimating requirements, see paragraph 17.

b. The regiment carries a reserve supply of gasoline in 5-gallon drums. Since this is the only reserve carried by the regiment, a number of these drums may be removed from vehicles and utilized to establish a rotating supply of filled drums at supply points of the regiment and battalion. A reserve supply of oil and grease, in containers, is usually carried on the battalion and company maintenance trucks and in the regimental maintenance section.

16. DISTRIBUTION. a. During movement, class III supply points may be established by the regimental service company or by higher headquarters along routes of march. At such points, resupply may be effected by exchanging empty for filled containers.

b. During combat, higher headquarters establishes at railheads and other convenient locations along the main supply routes, class III supply points where regimental vehicles operating along these routes are serviced with gasoline and oil. Vehicles operating within the regimental area are usually resupplied with gasoline and oil from the regimental class III supply point which is established in the regimental train bivouac. Filled containers are brought to this point from class III supply points in rear by service company vehicles.

c. (1) When practicable, gasoline and oil should be distributed at more forward supply points. When available, filled containers may be distributed to regimental and battalion ammunition supply points, in order to refill vehicles coming to these establishments and to exchange filled containers for empty ones. Filled containers may also be sent forward when meals are delivered to troops.

(2) Filled gasoline containers placed at supply points should be dispersed in several locations to prevent excessive loss by the explosion of a single bomb or shell.

d. Battalion and separate company commanders are kept informed of the location and time of opening of class III supply points established by the regiment and higher headquarters. When notified that sufficient containers are not available to provide the distribution described in c above, battalion and separate company commanders dispatch one or more company vehicles, with empty containers to

be refilled or exchanged for filled ones, to the most conveniently located class III supply point.

e. The method of distributing class III supplies varies with the situation. Every effort is made to simplify and expedite distribution. The service company commander, assisted by the regimental motor officer, carries out the distribution of class III supplies as directed by the regimental supply officer.

17. ESTIMATED EXPENDITURES. a. Advance estimates of gasoline and oil requirements should be made daily by supply officers. Estimates of future gasoline expenditures are usually figured in terms of the "unit mile," but are transmitted to the next higher authority in terms of gallons. The unit mile is the amount of gasoline in gallons required to move all vehicles of the unit one mile. Each officer responsible for unit supply determines his unit mile. Estimates take into account the following:

(1) Types and number of vehicles likely to be used.

(2) Distances likely to be traveled in any movement of the unit as a whole, in probable supply activities, and in reconnaissance and other activities.

(3) Gasoline for kitchen ranges.

b. Oil requirements in gallons are calculated normally at 3 percent of gasoline requirements in gallons.

c. Regardless of estimated requirements, fuel tanks and reserve containers of all vehicles are refilled each day, if practicable.

d. For logistical data, see FM 101-10.

Section IV.

CLASS IV SUPPLY

18. GENERAL. a. Class IV supplies normally comprise articles for which allowances are not prescribed by Tables of Equipment and the demands for which are directly related to the operations contemplated or in progress (except articles in classes III and V), such as fortification materials, construction materials, and machinery. Engineer fortification material and signal supplies are the principal class IV items of concern to infantry units. (See fig. 1.)

b. In general, class IV supplies (miscellaneous) are usually obtained by requisition on the basis of actual or estimated requirements.

c. Articles of any class may, by reason of special stringency, be transferred to class IV pending the reestablishment of normal supply status for these articles.

19. ENGINEER. When a position is to be organized for defense, the supplies required by regiments for maintaining and improving field fortifications are placed at the army engineer supply point, usually without being requisitioned. Supplies are obtained at this point and distributed to units by regimental

train vehicles in accordance with instructions of the regimental supply officer. The regimental supply officer notifies subordinate units when and where engineer material will be delivered to working parties, and arranges for delivery. Ordinarily, he has the service company commander take charge of the procurement and distribution of tools and fortification materials, and the recovery of the tools after they have served their purpose.

20. SIGNAL. The division signal officer may establish a supply point within the division area to store temporarily quantities of supplies (such as wire), which are estimated to be required for an operation, but which cannot be carried initially by subordinate units and which must be delivered during combat. Normally supply will be direct from army to using units. The division signal officer arranges with the army signal officer for units to draw supplies. The service company is usually charged with procuring signal supplies from the higher echelon and delivering them to the companies concerned.

Section V

CLASS V SUPPLY

21. GENERAL. a. Class V supplies include ammunition, pyrotechnics, antitank mines, and chemicals. (See fig. 1.)

b. (1) Requirements and supply procedure depend upon the tactical situation. As a general procedure, ammunition is trucked as close to the using weapons as possible. When a unit empties an ammunition carrying vehicle, this vehicle is sent immediately to the ammunition supply point of the next higher unit with a request for the amount and types of ammunition desired. Each unit commander is responsible for supplying his subordinate units with class V items after they have been made available to him. In all situations, subordinate leaders keep the next higher commander informed of the status of ammunition supply. The *ideal* situation is to have at all times, within easy access to machine-gun, mortar, howitzer, and antitank gun positions, an amount of ammunition equal to expenditures expected to be made from those positions *in addition to the prescribed loads of unit vehicles*. The *practical* solution is to approach the ideal as closely as available transportation and ability to predict expenditures will permit. Only enough am-

munition is unloaded at successive weapon positions and supply points to meet the probable needs prior to further advance.

(2) When the situation warrants, any vehicle of the regiment may be employed in the procurement and distribution of ammunition. Personnel in support or reserve units may be employed by the commander thereof to assist in hand-carrying ammunition to forward elements of his unit. The ammunition in the possession of dead or wounded, on un-serviceable vehicles, or near weapons that are incapable of being fired, will be recovered and employed by the nearest individual or unit. Captured ammunition and weapons should be employed to the greatest practicable extent; however, captured automatic weapons having a distinctive sound should be employed only when friendly troops in the immediate vicinity have been informed that they are to be used.

c. Units are provided with sufficient ammunition prior to contact with the enemy to enable them to initiate and sustain combat until replenishment from the rear can be effected. (See par. 3a.) This initial supply of ammunition for infantry units is carried on individual soldiers, company weapon carriers and prime movers, and on vehicles of the regimental ammunition train.

22. PROCUREMENT BY REGIMENT. a. Class V supplies are normally made available in the form of credits at designated army supply points for a

stated period or operation. The division commander makes allocations to subordinate units. The regiment secures ammunition within the limits of its credits by calls on designated army supply points and reports the amounts actually obtained to the division ordnance officer. The latter keeps the record of allocations and of drafts made therefrom. The status of ammunition is determined by periodic reports from combat units. Except in emergencies, the regimental munitions officer (see par. 4c) will ordinarily use ordnance department forms in drawing ammunition, and in making reports on status of ammunition supply and any other reports or records required. He must be familiar with ammunition code symbols as published in ordnance SNL's (standard nomenclature lists) for ammunition used within the regiment. These code symbols are for the purpose of designating types of ammunition and are used on all ammunition forms, records, and reports. See FM 9-6 for an explanation of ordnance ammunition forms and code symbols.

b. Labor for loading ammunition vehicles at army supply points is furnished from army personnel.

23. AMMUNITION SUPPLY POINTS. a. Characteristics. Desirable characteristics of regimental and battalion ammunition supply points are:

- (1) Convenience to units served.
- (2) Location at or in rear of the point where routes to subordinate units diverge.

(3) Defilade from hostile small-arms fire and suitability for defense against mechanized attack.

(4) Concealment from air and ground observation.

(5) Ease of identification by friendly troops.

(6) Facility of motor movement to the rear.

(7) Adequate space for truck turn-around and transfer of loads.

b. Operation. (1) The munitions group of the service company, headed by the regimental munitions officer under the supervision of the regimental supply officer, operates the regimental ammunition supply point, takes charge of ammunition vehicles when these vehicles are under regimental control, and directs their prompt loading and release to battalions and separate companies. Emptied ammunition train vehicles are dispatched to the army ammunition supply point for refill as authorized by the division ordnance officer.

(2) Labor for transferring loads at regimental ammunition supply points is furnished by personnel from battalion ammunition and pioneer platoons, if available; otherwise by personnel designated by the regimental commander for that purpose. Labor for transferring loads at battalion ammunition supply points is furnished by personnel from the ammunition and pioneer platoons of the respective battalions.

c. Security. (1) The regimental munitions officer is responsible for safeguarding the regimental ammunition supply point. He uses any means that are available within the installation; if the need for added security means is indicated, he makes specific recommendations to the regimental S-4.

(2) The battalion S-4 is charged with safeguarding the battalion ammunition supply point. He uses personnel from the battalion ammunition and pioneer platoon for this purpose.

(3) Measures taken for the security of ammunition supply points are similar to those taken for the regimental train bivouac area. (See par. 57e.)

d. Route of ammunition advance. During offensive action, regimental and battalion ammunition supply points are advanced by bounds along predetermined routes whenever displacement becomes necessary in order to provide continuous close support to units of the attacking echelon. This predetermined route is called the *route of ammunition advance* and is prescribed in all offensive situations. It starts with the initial location for the ammunition supply point and continues to include a probable location from which to serve troops on the final objective. Its purpose is to insure that units of the attacking echelon, which send back for ammunition, will not fail to locate the supply point even though it may be in the process of displacing.

CO CMDRS MAKE REQUIREMENTS FOR AM AND HAND-CARRY KNOWN TO BN.
 SUP SGT OPERATES CO AM SUP PT.
 PLAT LEADERS RESPONSIBLE FOR HAND-CARRY TO WEAPONS. KEEP CO CMDR INFORMED AS TO STATUS OF SUPPLY.
 NOTE: IN HV WPN CO, T NCO'S CONTROL MOVEMENT OF WPN CARRS. SEE FM 7-15.

BN S-4 ESTABLISHES AND OPERATES BN AM SUP PT. ASSISTED BY BN SUP SGT. BN MTR O AND AM & PION PLAT. RESPONSIBLE FOR MOVEMENT OF AM FROM REGTL AM SUP PT TO CO AREAS.

REGTL MUN O ESTABLISHES AND OPERATES REGTL AM SUP PT.
 REFILLS EMPTY AM VEHICLES AT REGTL AM SUP PT OR CONDUCTS THEM TO ARMY AM SUP PT FOR REFILL. OBTAINS APPROVAL OF AM REQUESTS AT DIV AM OFFICE (DAO).

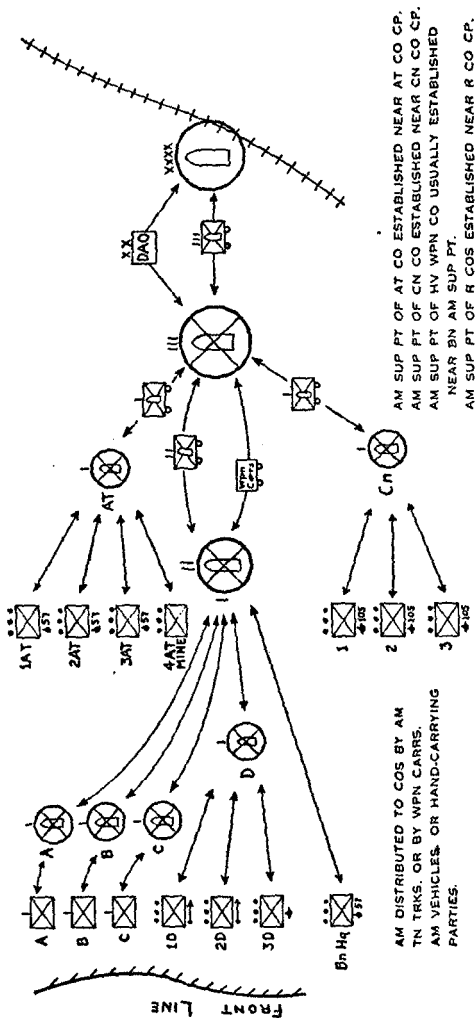

Figure 3. Ammunition supply, infantry regiment, schematic.

24. ROUTE MARCH. a. The ammunition train and company transport of rifle and heavy weapons companies move with the regimental motor column in rear of the foot elements. If the regiment marches in more than one column, the motor elements of each column march in rear of the foot elements to which they belong. In a movement entirely by motor, company transport accompanies its own unit. When the ammunition train and company transport are under regimental control, they are usually commanded by the motor transport officer. Prime movers and ammunition vehicles of the antitank company and the cannon company move as required by the missions of their respective units. When a battalion leaves the regimental column, its ammunition train is released to it along with its company transport.

b. When contact with enemy ground forces is remote and after extra ammunition has been issued (par. 26b(1)), advance guard company transport and ammunition train vehicles move by short bounds, under control of the advance guard commander, immediately in rear of the foot elements of the main body and in advance of the regimental motor column. When contact with enemy ground forces is imminent, weapon carriers are moved forward and released to companies.

25. APPROACH MARCH. a. Battalions in the leading echelon are accompanied by their company transport and ammunition trains. Weapon carriers must be readily available to their units and move

under company control when practicable. Extra ammunition may be issued before the approach march begins.

b. The company transport of rear battalions moves under company or battalion control. Battalion ammunition train vehicles move under battalion or regimental control. If extra ammunition is to be issued before the approach march begins, ammunition carrying vehicles are released to the companies concerned. As soon as the issue is completed, ammunition train trucks are returned to battalion control. When the company transport and ammunition train move under battalion control, they are usually commanded by the battalion supply officer. When the duties of the battalion supply officer require his presence elsewhere, the command of these vehicles is usually delegated to the battalion motor transport officer.

26. ATTACK. a. When practicable, assembly positions (areas) are occupied preliminary to deployment for attack. In them the attack is organized and coordinated, equipment not essential to combat disposed of, and extra ammunition issued if this has not already been done. Attack orders are usually issued before departure from the assembly positions. These orders normally include the location of ammunition supply points, the routes of advance for ammunition, and the disposition of company transport and ammunition train vehicles.

b. (1) Prior to entry into combat, riflemen are issued "extra ammunition" from that carried on ammunition train vehicles. Extra ammunition is that additional quantity of small-arms ammunition and grenades issued to riflemen, automatic riflemen, and rifle grenadiers to augment that which they normally carry on the person. To issue this ammunition, ammunition train vehicles are usually released to companies. At the same time, all or part of the ammunition carried on ammunition train vehicles for crew-served weapons may be distributed to company ammunition bearers or weapon carriers as prescribed by the company commander. Ammunition train trucks are returned to the battalion ammunition supply point immediately after extra ammunition is issued. The loads of partially emptied trucks are consolidated, or in some situations are dumped, in order to empty vehicles for immediate dispatch to the regimental ammunition supply point for refill. The loaded trucks are usually held at the battalion ammunition supply point until emptied, but may be moved forward along the route of ammunition advance. As soon as emptied, each ammunition truck is sent to the regimental ammunition supply point for refill.

(2) The battalion S-4 is charged with the establishment and operation of the battalion ammunition supply point, procurement of ammunition from the regimental ammunition supply point, movement of ammunition vehicles between the battalion ammunition supply point and the regimental ammunition

supply point, and delivery of ammunition to the units of the battalion. For the execution of these tasks, he uses the battalion motor transport officer, the battalion supply sergeant, and the ammunition and pioneer platoon.

(3) The movement of ammunition forward of the battalion ammunition supply point will be effected by weapon carriers, when practicable. To facilitate such movement, the battalion motor transport officer is required to keep in touch with the weapon carriers of all combat units and to supervise, coordinate, and expedite their movements within the battalion area. It is not expected that he will personally control movements of individual vehicles or groups of vehicles; he will normally effect coordination by instructions to representatives of the unit commanders concerned.

(4) When hand-carrying of ammunition is necessary to place it in company areas, this work usually is performed by members of the ammunition and pioneer platoon. When necessary, members of the platoon may be attached to companies to assist in hand-carrying ammunition within their areas. The ammunition and pioneer platoon leader supervises his personnel while executing their ammunition supply tasks. He assigns duties to members of the platoon in accordance with the requirements of the situation after consultation with the battalion S-4. The ammunition and pioneer platoon operates from the battalion ammunition supply point. See FM 7-10, 7-15, and 7-20 for further details pertaining to ammunition supply in the battalion.

(5) All company commanders are responsible for distributing ammunition to their platoons forward of the point of delivery by the next higher echelon.

c. Ammunition is made available by the regiment at the regimental ammunition supply point to representatives of the battalions, the antitank company, and the cannon company, who are responsible for its delivery to company and platoon areas. Procurement of ammunition by the regiment is effected by ammunition train vehicles and such other available vehicles as the situation requires. The organic ammunition vehicles of subordinate units that are of large tonnage capacity may be employed by the regiment to assist in hauling ammunition for their respective units from the army ammunition supply point. When the means within the regiment are inadequate to accomplish these results, application should be made to division for additional trucks or closer support by the ammunition supply agency. (See par. 3b(5).)

d. (1) The regimental ammunition supply point is established and operated by the regimental munitions officer as described in b and c above.

(2) When required by the situation, one or more battalions may be directed to return all ammunition train vehicles to the regimental ammunition supply point. Ordinarily, ammunition train trucks are not unloaded at the regimental ammunition supply point unless the probability of heavy expenditures makes it advisable to send all or part of them back

for additional ammunition. When ammunition is to be stocked at the regimental ammunition supply point, labor details must be provided. These details are obtained from battalion ammunition and pioneer platoons or other available units.

(3) As the attack progresses, the battalion and regimental ammunition supply points are displaced as indicated in paragraph 23d. Locations on the announced routes of ammunition advance are reconnoitered in advance.

e. (1) Ammunition for the antitank company essential to initiate combat is carried for each gun on its prime mover and on the company headquarters ammunition vehicle. Because of the limited mobility of the antitank gun when moved by hand, the prime movers should normally remain under cover near the gun positions. Squad ammunition bearers carry ammunition from the vehicles to the weapons. When the situation permits, the company ammunition vehicle may be used to resupply ammunition to the vicinity of the gun positions. If replenishment in larger quantities is necessary, arrangements must be made to secure a vehicle from the regimental train.

(2) The initial supply of antitank mines is carried on the cargo vehicles of the antitank mine platoon. Replenishment of mines is effected by routing these vehicles through the company ammunition supply point to the regimental ammunition supply point, and, if necessary, from there to the army am-

munition supply point, where they are refilled and returned to the platoon through the same installations.

(3) The antitank company ammunition supply point is usually located in the vicinity of its company command post. See FM 7-35 for further details pertaining to ammunition supply for the antitank company.

f. (1) Ammunition for the cannon company essential to initiate combat is carried for each howitzer on its prime mover and on platoon headquarters ammunition vehicles. In combat all the vehicles remain under platoon control and are held in the platoon firing position areas as close to the firing positions as the terrain permits, except when platoon ammunition vehicles are engaged in the resupply of ammunition, or when control is assumed by the company commander. Control by the company commander may be dictated when one platoon has suffered vehicle losses which necessitate employing the vehicles of another platoon for its supply. The section prime movers are refilled from the platoon ammunition vehicles or from platoon supply points established in the vicinity of the platoon or section firing positions. When a platoon ammunition vehicle is emptied, the platoon leader dispatches it to the company ammunition supply point.

(2) When an emptied platoon ammunition vehicle reports to the company ammunition supply point, it is directed or conducted to the regimental

ammunition supply point. At this point, ammunition may be replenished from a reserve which has been dumped previously or by exchange of the emptied vehicle for a filled one. If no ammunition is available at the regimental ammunition supply point, the emptied vehicle will be conducted to the army ammunition supply point under regimental control, refilled, returned to the regimental ammunition supply point, and released to company control.

(3) The company commander is responsible for the initial supply and resupply of ammunition for the company. Records of ammunition expenditures are kept by chiefs of section, platoon leaders, and the company commander in order to insure accurate information as to the status of ammunition supply within the company at all times. The company commander selects and establishes the company ammunition supply point. Its location will usually be near the company command post in order to take advantage of the company communication net.

(4) The tonnage involved in the supply of ammunition for the cannon company is so great that requirements must be anticipated. When the regiment uses vehicles other than those assigned to the cannon company for hauling howitzer ammunition from the army ammunition supply point, these vehicles are usually released to the cannon company commander until their loads have been distributed in order to avoid transferring loads. See FM 7-37 for further details pertaining to ammunition supply for the cannon company.

27. RAPIDLY MOVING SITUATIONS. In rapidly moving situations, the status of ammunition supply within the regiment should be determined, necessary replacement effected without delay, and the plans of higher headquarters ascertained relative to the establishment of ammunition supply points along the route to be followed so that contemplated requirements may be anticipated. When the establishment of convenient army ammunition supply points is not contemplated, the regimental commander requests the necessary additional ammunition and transportation to accomplish his assigned mission. In all other details, the supply of ammunition in a rapidly moving situation is similar to that prescribed for the attack, except that ammunition should be retained mobile on vehicles to an even greater extent than in the attack.

28. DEFENSE. In defense, the method of ammunition supply varies in the following particulars from that used in attack:

a. No routes of ammunition advance are prescribed.

b. (1) Initial loads of ammunition vehicles and an *additional* reserve will be placed on the position. Initially, the minimum tonnage to be unloaded on a position is sufficient to obviate replenishment prior to dark. These stocks are usually placed on the ground near initial, alternate, and supplementary

weapon positions. In some situations, it may be advisable to create small battalion and regimental stock piles as ammunition reserves.

(2) In the absence of a specific directive, the quantity of ammunition to be placed in the regimental sector is determined by the regimental commander based on his estimate of the situation. This estimate includes such factors as ammunition allocations; probable time, type, location, and duration of combat; distance to ammunition supply points; and transportation available. After contact is made with the enemy, replenishment of ammunition to and within the companies will usually be made under cover of darkness.

c. When the position is being occupied out of contact with the enemy, ammunition train and other available cargo vehicles may be employed under regimental control to haul ammunition from the army ammunition supply point to the battle position. In executing this task, the regiment employs the minimum number of available vehicles of large capacity rather than a large number of vehicles of small capacity, in order to reduce traffic congestion in rear areas and at the army ammunition supply point.

d. Usually, loads of ammunition train vehicles are delivered to company areas. When this is impracticable, weapon carriers are employed to complete delivery of ammunition from the regimental or battalion ammunition supply points to company areas.

e. Vehicles not required in the defense of the forward areas are withdrawn to the regimental train bivouac or other suitable location where their prescribed loads are reconstituted with ammunition hauled from the army ammunition supply point in any available large capacity vehicles. After the prescribed amounts of ammunition for the reserve battalion(s), the antitank company, and the cannon company have been placed on the positions, all or part of the vehicles of these units are refilled. Vehicles other than ammunition train vehicles may be left in the forward area under unit control so as to insure availability of a mobile supply of ammunition and transportation for these units. Availability of defilade and concealment and the probable future use of vehicles are factors to be considered in determining which vehicles are to be left in the forward area.

29. RETROGRADE MOVEMENTS. Plans for ammunition supply in a retrograde movement should insure the following:

a. **Supply of covering force.** Ammunition for the covering force may be provided by transfer from other units or by release of certain ammunition train vehicles. A careful estimate of probable needs is imperative to avoid replenishing, abandoning, or destroying ammunition when the covering force withdraws.

b. **Supply of delaying units.** Delaying units provide themselves with such stocks of ammunition as they are able to move from the initial position. They

may also pick up limited additional stocks placed for them along the route of withdrawal or on selected delaying positions.

c. Establishment of stock on new position. The plan for placing stocks of ammunition on the new position will be determined by the mission and the tactical situation.

30. LANDING OPERATIONS. a. Initial supply. Individuals and units are usually issued, prior to debarkation, sufficient ammunition to sustain combat for 1 or 2 days. Initial unit reserves of ammunition, from 3 to 5 days supply for all troops, are combat-loaded with each battalion combat team. These initial reserves are segregated prior to loading and are stowed so as to be immediately available to follow assault troops ashore.

b. Resupply. The weight and bulk of certain types of ammunition initially carried ashore by assault units prevent all of this ammunition being carried into action. That which is left on the beaches is assembled under battalion control into small unit piles, and constitutes battalion ammunition supply points; these subsequently pass to regimental control as the service company comes ashore and battalions move inland. Until transportation is landed, resupply of assault units is necessarily by hand-carry, possibly augmented by confiscated transport (motor or animal) found in the zone of action. As the beachhead is extended, and motor transportation landed, ammunition supply conforms to the principles of offensive action.

Chapter 3

MAINTENANCE, REPAIR, AND OTHER ACTIVITIES

31. MOTOR MAINTENANCE. a. **General.** The maintenance of motor vehicles is conducted in conformity with FM 25-10 and AR 850-15. Maintenance within the regiment is normally limited to first and second echelon maintenance. For echelons of motor maintenance, see appendix III.

b. **First echelon maintenance.** First echelon maintenance is that performed by truck drivers using tools and supplies available on their vehicles. It includes correct driving; servicing with gasoline, oil, water, and air; inspecting; cleaning and lubricating; tightening and minor adjustments; and care of tools and accessories. The commander of each company to which motor vehicles are organically assigned is responsible for the direction and supervision of first echelon maintenance of those vehicles. He assigns definite maintenance duties to truck drivers and prohibits them from doing other maintenance work except in emergencies. The truck driver is responsible to the company commander for preventive maintenance functions within the limits of his ability and the time and equipment available to him. He

inspects his vehicle before, during, and after each operation and reports defects. The company commander makes regular inspections of his company's vehicles and causes appropriate adjustments beyond the capabilities and facilities of the company to be reported to the battalion commander (battalion motor transport officer).

c. Second echelon maintenance. Second echelon maintenance is a regimental function which provides for preventive maintenance, minor repairs, unit replacement, inspections, lubrication, supply, battle-field recovery, and evacuation. Within the regiment, there are two groups responsible for this maintenance. In each company, except rifle companies, there is a company automobile mechanic who is responsible for maintenance of company vehicles, the battalion headquarters company automobile mechanic being responsible for maintenance of the rifle company vehicles in his battalion. All work which cannot be performed by company mechanics is passed on to the regimental maintenance section. It is always advisable to have maintenance operations performed by the lowest echelon capable of performing the operation.

d. Third, fourth, and fifth echelon (service) maintenance. This maintenance is normally performed by ordnance personnel. Vehicles requiring service maintenance are ordinarily reported to the supporting third echelon unit and immediate steps taken to have them evacuated for repair or replacement. In emergencies, the service company may have to perform some third echelon maintenance.

e. Inspections. It is the duty of all commanders to make regular and frequent inspections of their motor vehicles and of the operating and maintenance activities of their commands. Maintenance inspections are made as prescribed by FM 25-10, AR 850-15, and TM 9-2810. Immediately upon joining a unit, all officers will be instructed by the next senior officer as to the details of the required inspections.

f. Maintenance during marches and combat. (1) During marches and tactical operations, every opportunity for performing motor maintenance is utilized. Company automobile mechanics ride at the rear of company transport groupings. During halts, they make preventive maintenance inspections, adjustments, and minor repairs. When a vehicle breaks down, a company automobile mechanic stops with it in order to diagnose the trouble and repair it, if practicable.

(2) During marches and in combat, the maintenance section of the service company is disposed so as to render the most efficient service to the regiment. The section usually marches at the tail of the regimental motor column.

(3) Temporary roadside repairs are often made to unserviceable vehicles so that they can reach their destination or the bivouac of the maintenance section (in regimental train bivouac), where further repairs are made. When a vehicle drops out, it is driven, pushed, or towed to the side of the road and

placed under any available cover. If possible, the trouble is diagnosed and repaired at this point. If the service company maintenance personnel decide that repair is impossible within the time limit imposed by the situation, the vehicle is either towed or abandoned. If towed, it is repaired when the unit halts or goes into bivouac. The decision to abandon a vehicle, either temporarily or permanently, is made only by an officer, or by a noncommissioned officer who has been given this authority. In route march, an abandoned vehicle is reported to the next higher headquarters in order that it may be picked up by a suitable maintenance or salvage unit. For the detailed procedure on abandonment, see FM 25-10.

(4) During combat, the maintenance section operates a mobile repair shop in the regimental train bivouac where unserviceable reparable vehicles are brought. Sometimes it is preferable to send repair crews to make repairs on such vehicles at the spot where rendered inoperative.

g. Maintenance forms. Forms, records, and reports are designed to serve necessary and useful purposes. Responsibility for the proper execution of these forms rests upon commanding officers of all units operating and maintaining motor vehicles. It is emphasized, however, that forms, records, and reports are merely aids. They are not a substitute for thorough practical work, physical check, and active

supervision. All types of forms will be found listed in AR 850-15. No forms other than those listed will be used in operating and maintaining motor vehicles without prior War Department approval.

32. EXPLOITATION AND BATTLEFIELD RECOVERY. a. **General.** Weapons, equipment and materiel, pertaining to both enemy and friendly troops, which are disabled, partially worn out, captured or abandoned, must be placed in supply and maintenance channels in order that this materiel can be used immediately, or be repaired and reissued. Besides making available considerable quantities of supplies for reissue, such action conserves equipment and materiel and lessens the burden on transportation and supply systems. Every individual must be indoctrinated with his responsibility with regard to disabled and abandoned property. All personnel taking possession of abandoned materiel will first insure that it does not contain booby traps and is not chemically contaminated. Booby traps will be disarmed and removed by personnel trained in this function. Chemically contaminated materiel will be decontaminated by recovery troops before use. Captured materiel which appears to be of new design, or to contain new materials, is turned over to the appropriate division supply service, which will in turn expedite its delivery to the next higher echelon for technical analysis.

b. **Recovery and evacuation.** Supply officers of regiment and battalion supervise recovery and salvage activities within their respective units. In gen-

eral, a salvaged item is not evacuated any further to the rear than is absolutely necessary. Salvaged articles are put into serviceable condition as soon as possible and as close to the front as practicable. Repairs are made on the spot to the maximum extent. All means must be employed to recover vehicles and other materiel, both our own and those of the enemy, which are serviceable or can be made serviceable within the combat zone before the fluctuation of battle permits the enemy to recover or destroy them. Usable stocks of all types of supplies which are discovered must be safeguarded and higher authority immediately notified of the general type, amount, and location of such supplies. Unit commanders are responsible that transportation returning from the front is fully used for salvage. They must see that no abandoned property is left behind. Arms and equipment accompanying the sick and wounded are collected by the salvage authorities at medical establishments. Salvage collecting points in locations favorable for transportation by empty vehicles moving to the rear are designated in administrative orders.

33. REPAIR AND REPLACEMENT OF EQUIPMENT. a. **Light weight ordnance equipment.** When the tactical situation permits, small arms, automatic weapons, and other light weight ordnance equipment requiring repair or replacement, which cannot be effected locally, are sent without delay through organization and unit supply echelons on vehicles which are proceeding to the rear for ammunition.

Exchange of ordnance equipment is usually effected at the ordnance collecting point which is established in the vicinity of the army ammunition supply point, though it may be accomplished at more forward locations. Repair is usually effected in the bivouac of the ordnance maintenance unit but may be accomplished at more forward locations.

b. Other light weight equipment. Companies usually send other light weight equipment requiring repair or replacement to the train bivouac by kitchen trucks or other transport going to the rear. Articles which cannot be repaired locally by armorer-artificers will be sent by the supply section of the service company to the appropriate division supply service, where repair or replacement is effected.

c. Heavy and bulky equipment. The extent of damage, and location of heavy and bulky equipment which it is impracticable to move, should be reported through maintenance or supply channels so that it may be repaired on the spot by personnel of the appropriate service, or replaced by a similar article.

34. DESTRUCTION OF VEHICLES AND OTHER MATERIEL. **a. General.** (1) When terrain is being abandoned to the enemy and the evacuation of motor vehicles and other equipment is impossible, such materiel must be destroyed, whether in operating condition or not, in order to deny its use to the enemy. The destruction of materiel is a command decision to be implemented only on authority delegated by the division or higher commander.

(2) When destruction is ordered, it must be accomplished with complete disregard for possible salvage by our own forces. Some factors which affect the thoroughness and completeness of destruction are:

(a) Personnel, materials, and equipment available.

(b) Number of vehicles, or amount of other equipment, to be destroyed.

(c) Time available in which to effect destruction.

(d) Time at which destruction will take place.

(e) Presence of terrain features which may aid destruction.

(f) Existence of vital information which might be disclosed to the enemy by failure to effect complete destruction of certain items.

(3) Destruction should be accomplished so far as the tactical situation will permit, as systematically as any other military operation. Specific means of destruction should be provided, since last minute improvisations are likely to prove ineffective. The working principles to be followed are:

(a) Methods for the destruction of materiel subject to capture or abandonment in the combat zone must be adequate, uniform, and easily followed in the field.

(b) Destruction must be as complete as the available time, equipment, and personnel will permit. If thorough destruction of all parts cannot be com-

pleted, the most important features of the materiel should be destroyed, and parts essential to the operation or use of the materiel and which cannot be easily duplicated should be ruined or removed. The same essential parts must be destroyed on all like units to prevent the enemy's constructing one complete unit from several damaged ones.

(4) To accomplish adequate and uniform destruction of materiel, all echelons must—

(a) Prepare plans for the destruction of materiel in the event of imminent capture. Such plans must be flexible as to the available time, equipment, and personnel. These plans should include several designated procedures arranged in order of their effectiveness. The factors listed in (2) above will determine which of these plans will be put into effect; the sequence outlined in the plan should be adhered to strictly.

(b) Be thoroughly trained in the use of all the prepared plans or methods of destruction. *This training will not involve the actual destruction of materiel.*

b. Destruction of motor vehicles. (1) GENERAL. Any method of destruction resorted to must be such as to prevent the enemy from putting the vehicle back in service with the means available to him in the combat zone. Every advantage should be taken of any feature of the terrain that might lend itself to vehicle destruction. Frequently a vehicle may be crashed into other vehicles, trees, walls, or banks,

or may be run over cliffs. This done, more complete destruction may be effected by demolishing parts as described above, and then setting fire to the wreckage. It may be possible to drive, push, or tow a vehicle onto a trash, rubbish, or brush heap, or to place combustible materials around the vehicle, and then to destroy it completely by fire. Destruction by fire may also be accomplished by placing the canvas cover under the vehicle, draining gasoline and oil from all the units thereon, and then setting fire to it. In other situations, the vehicle may be pushed into a body of water deep enough to submerge it completely.

(2) METHODS. The following methods of destruction of motor vehicles are listed in the order of effectiveness:

(a) *Method No. 1.* Remove and empty portable fire extinguishers. Puncture the fuel tank. Place one 2-pound TNT charge on top of clutch housing and one on left side of engine as low as possible. Insert tetryl nonelectrical caps with at least 5 feet of safety fuze in each charge. Ignite the fuze and take cover. Elapsed time: 4 to 5 minutes if charges are prepared beforehand and carried in the vehicle.

Note: If charges are prepared beforehand and carried in the vehicle, *keep the caps and fuzes separated from the charges until used.*

(b) *Method No. 2.* Remove and empty the portable fire extinguishers and puncture the fuel tank. Fire on the vehicle, using antitank or other artillery

or antitank rockets or grenades. If a good fire is started, the vehicle may be considered destroyed. Elapsed time: about 5 minutes per vehicle.

(c) *Method No. 3.* Remove and empty portable fire extinguishers and puncture the fuel tank. Smash all vital elements (such as distributor, carburetor, radiator, engine block, air cleaners, generator, control levers, crankcase, and transmission) with ax or pick (found in the pioneer set). Pour spare gasoline, oil, or distillate over the entire unit and ignite.

(3) METHODS OF DESTROYING PNEUMATIC TIRES. (a) *Method No. 1.* Ignite an M14 incendiary grenade under each tire. To insure best results when this method is combined with destruction of trucks by TNT, be certain that incendiary fires are well started before detonating the TNT.

(b) *Method No. 2.* Damage the tires with an ax, pick, or heavy machine gun fire (deflate them before doing this, if possible). Pour spare gasoline on tires, dousing each one, and ignite. When used in conjunction with wheeled vehicle destruction the ensuing fire will adequately destroy the vehicle.

c. Destruction of other equipment. (1) GENERAL. The same general principles as are covered in preceding paragraphs for the destruction of abandoned motor vehicles apply, with appropriate modifications, for the destruction of other items of equipment. For detailed description of methods, see field manuals of the 23-series, and technical manu-

als for specific items of equipment. The exact methods used will depend upon the means available.

(2) MACHINE GUNS, MORTARS, INDIVIDUAL WEAPONS, AND AMMUNITION. (a) The firing pin points of all small arms, except the revolver, can be broken by inserting the points into the holes in the face of the bolt and bending. Barrels of the M1, M1903, and M1917 rifles, the Browning automatic rifles, and carbines, can be bent by grasping the butt with both hands and swinging the barrel against a tree, rock, or firm ground.

(b) The barrels of caliber .45 submachine guns and of caliber .30 and caliber .50 machine guns cannot be easily bent under field conditions. Parts essential to the operation of the guns should be removed and destroyed. The same essential parts must be destroyed on all like units to prevent the enemy's constructing one complete unit from several damaged ones. Field strip machine guns; then, using the barrel as a sledge, destroy the cover, back plate, lock frame, and barrel extension. In the same manner, destroy machine gun mounts.

(c) Mortar tubes may be destroyed by using a mortar round or incendiary grenades. If evacuation is possible, carry the sights; if evacuation is not possible, thoroughly smash them.

(d) Ammunition may be destroyed by burning. Large caliber ammunition (37-mm or larger) can be destroyed by sympathetic detonation, using TNT.

(e) Fire control equipment is difficult to replace. It should be the last equipment to be destroyed.

Chapter 4

MEDICAL SERVICE AND EVACUATION

35. GENERAL. a. The medical and casualty evacuation service within the infantry regiment is provided by the regimental medical detachment. For details of the organization of the detachment, and duties of its personnel, see chapter 7.

b. For military sanitation, see FM 21-10. For first aid for soldiers, see FM 21-11. For medical service and evacuation within the infantry division and regiment, see FM 8-5, 8-10, and 100-10. For field sanitation, see FM 8-40. For records of sick and wounded, see FM 8-45. For splints, appliances, and bandages, see FM 8-50. For medical reference data, see FM 8-55.

36. MISSION. The mission of the medical detachment is to conserve the fighting strength of the regiment. This is accomplished by—

a. Preventive medical and sanitary measures and appropriate medical, surgical, and dental treatment.

b. Evacuation of sick and wounded personnel to battalion or regimental aid stations by personnel of

the detachment, where they are received, sorted, and given temporary care and such emergency treatment as limited facilities will permit. Those cases requiring further treatment are evacuated to collecting stations by collecting units of the division medical battalion.

37. EVACUATION WITHIN THE REGIMENT. a.

Casualties are given emergency treatment by company aid men until litter bearers are able to remove them to the aid stations.

b. Casualties in units not organically a part of battalions are evacuated by the nearest aid station or medical installation upon notification by the platoon leader or company commander concerned.

38. AID STATION. a. General. An aid station is an installation for the treatment of the sick and injured, established under combat conditions by a section of the unit medical detachment. (See FM 8-10.) The headquarters section and each of the battalion sections are equipped to establish and operate an aid station as follows:

(1) The regimental aid station ordinarily serves the regimental headquarters and such elements in its vicinity as are not served by battalion aid stations. (See also par. 60a(1)(d).) It is in the same echelon of evacuation as battalion aid stations and does not normally form a link in the chain of evacuation from battalion aid stations. However, it may

take over casualties of a battalion aid station that is forced to move before these casualties can be evacuated. It may be established in the area of the regimental reserve so that the section with the reserve may remain in readiness for movement. In some situations, the regimental aid station is not established, and headquarters section personnel may be used elsewhere. This group serves as a source of replacement and reinforcement for the battalion section.

(2) A battalion aid station is established by a battalion section to serve a battalion, including any supporting personnel in the battalion area.

b. Considerations affecting selection of site. (1) Desirable features sought in selecting an aid station site (fig. 4) are—

- (a) Protection from flat-trajectory fire.
- (b) Convenience to troops being served.
- (c) Concealment.
- (d) Economy in litter carry.
- (e) Proximity to natural lines of drift of walking wounded.
- (f) Accessibility to supporting medical troops.
- (g) Facility of future movement of the station to the front or rear.
- (h) Proximity to water.
- (i) Protection from the elements.

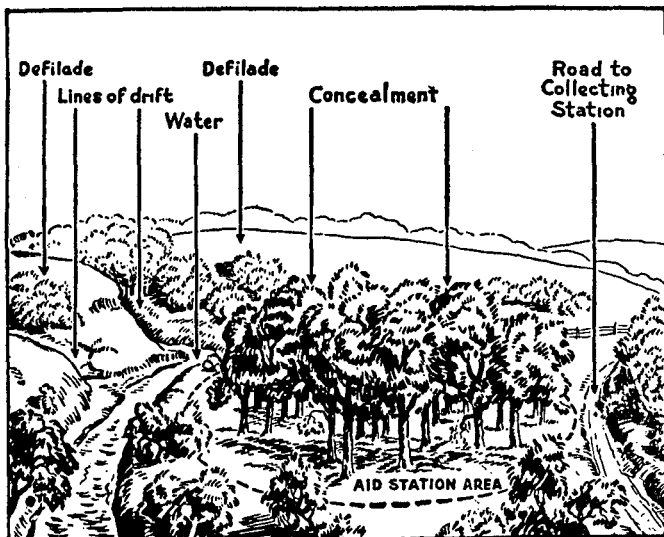

Figure 4. Aid station site; desirable features.

(2) Terrain features or military establishments that invite enemy fire or air attack are avoided as sites for aid stations. (See fig. 5.) Especially to be avoided are prominent landmarks; bridges; fords; important road intersections; heavy weapons, howitzer, and artillery firing positions; and ammunition and other supply points.

DO NOT LOCATE AN AID STATION—



NEAR A PROMINENT LANDMARK

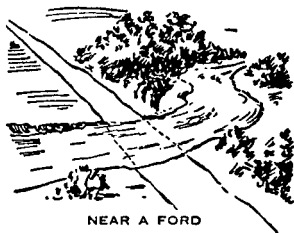

NEAR A FORD

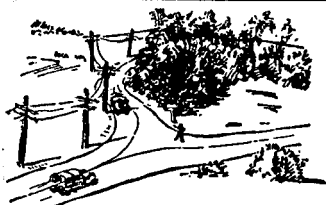

NEAR AN IMPORTANT ROAD JUNCTION

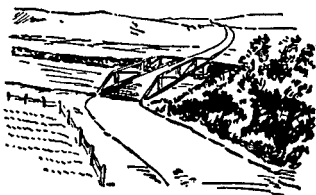

NEAR A BRIDGE

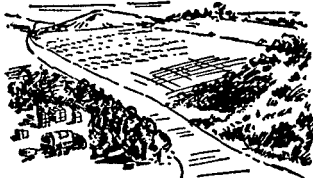

NEAR AN AMMUNITION SUPPLY POINT



WHERE IT IS EXPOSED TO DIRECT FIRE

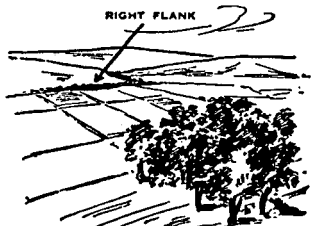

NEAR AN EXPOSED FLANK



NEAR A BATTERY POSITION

Figure 5. Aid station site; features to be avoided.

c. Functions. The functions of an aid station are—

(1) Receiving and recording casualties.

(2) Examining and sorting casualties and returning the fit to duty.

(3) Dressing or redressing the wounded (treatment limited to that necessary to save life or limb and to prepare patients for evacuation for short distances), and administering narcotics, blood plasma, and prophylactic toxoids.

(4) Furnishing venereal prophylaxis.

(5) Furnishing prophylaxis and treating men suffering from shock and exhaustion with hot food and drinks.

(6) Providing temporary shelter for casualties, when practicable.

(7) Transferring evacuees from the aid station to the supporting medical echelon (usually to ambulances or litter bearers of a collecting company).

d. Procedure, arrangement, and equipment. For aid station operating procedure, see paragraphs 41 to 45 inclusive, and FM 8-10. For a type arrangement, see FM 8-10. For aid station equipment, see Table of Equipment.

39. MEDICAL SERVICE DURING ROUTE MARCH.

a. During marches, the regimental surgeon accompanies regimental headquarters. The headquarters section usually marches with that part of the regimental trains accompanying the combat units.

b. Battalion medical sections accompany their battalions, the battalion surgeon with the battalion command group and company aid men with their respective companies. The medical assistant, MAC, the aid station squad, and the litter bearers march in rear of the foot elements of their battalion. Medical vehicles with the aid station equipment move with vehicles of the motor column.

c. Motor ambulances from the ambulance platoon of the collecting company of the division medical battalion are attached to marching troops for the collecting and evacuation of march casualties. When attached, the ambulances are under direct control of the regimental surgeon. If but one ambulance is with the regiment, it follows the headquarters section of the regimental medical detachment at the rear of the column. If additional ambulances accompany the column, they may be placed at the rear of battalion medical sections. On development of the regiment, ambulances revert to division control.

d. Sick and disabled soldiers are ordinarily given permission by squad leaders to fall out of the marching column and report to the company officer marching in rear of the company. Company aid men render such emergency treatment as is required. The company officer marching in rear of the company may direct the soldier to report to the medical assistant, MAC, at the next halt, or he may issue a permit authorizing him to drop out of the column and await the arrival of the medical assistant, MAC. The medical assistant, MAC, marching with the

medical section in rear of the foot elements of the battalion, examines such individuals. He returns permits to the company commanders concerned, showing thereon the disposition of soldiers examined.

e. March collecting posts are established by the collecting company of the division medical battalion, evacuation being by motor ambulance. When higher headquarters announce that such posts are to be available for a particular march, the regimental surgeon advises battalion surgeons, who utilize these posts to relieve the unit of noneffectives.

f. Advance, flank, and rear guards are furnished an appropriate detachment from the medical section of the battalion concerned when the security elements are sufficiently large to warrant such action. This detachment may be augmented by additional personnel, supplies, and transportation from the medical detachment headquarters section or from the division medical battalion.

40. MEDICAL SERVICE DURING APPROACH MARCH AND IN ASSEMBLY AREAS.

a. During the approach march, company aid men closely follow their assigned companies. Litter bearers are deployed to cover the widening battalion front. The remainder of the section marches along the axis of advance in extended order, hand-carrying aid station equipment, if necessary. The battalion surgeon remains with the battalion commander as long as possible in order to keep himself informed of developments in the situation. (See FM 7-20.)

b. In the assembly area, company aid men are with their assigned companies. If necessary, they obtain additional supplies for their medical pouches from the aid station. The aid station group, less the battalion surgeon, remains in a state of readiness. The litter bearers are issued litters and additional dressings. The battalion surgeon remains with the battalion commander and staff until all details of the battalion order are completed and the order issued. He then returns to the site of his battalion station and issues his order.

41. MEDICAL SERVICE DURING DEVELOPMENT AND ATTACK. a. Initial dispositions. (1)

Upon development of the regiment, the transportation of each battalion medical section joins its respective section. If motor vehicles cannot continue moving forward, the packs containing the essential equipment are slung and carried to the aid station sites. Detailed orders are issued to medical personnel. The initial locations of the battalion aid stations are designated in the battalion attack order. For duties of personnel, see FM 7-20.

(2) As battalions move forward for combat, company aid men and litter bearers follow designated companies.

(3) Aid station personnel move to the initial aid station location, but remain prepared to move forward unless developments require the immediate establishment of the station at that site. Reconnaissance

sance for new aid stations starts as soon as the advance of the attacking echelon has made suitable sites available.

b. Attack. (1) During the attack, company aid men follow by bounds in rear of leading platoons, locate and tag the wounded, and administer emergency treatment. Walking wounded are directed to the aid station. Locations of those unable to walk are indicated to litter bearers or are marked. Litter bearers search the area for wounded and carry non-walking wounded to the aid station. While the aid station squad is advancing behind the attack, its personnel search the area for casualties. When the number of casualties justifies it, the aid station is set up, but only necessary equipment is unpacked. When the aid station displaces, nonwalking wounded are left in groups to be picked up by collecting personnel of the division medical battalion. If necessary, an attendant is left with the group.

(2) The headquarters section of the medical detachment is kept mobile as long as possible in the vicinity of the regimental command post. It maintains contact with battalion aid stations and with the division collecting stations. Casualties occurring nearby are given treatment by the headquarters section. Equipment is unpacked and a regimental aid station set up when required.

(3) It is normal for regimental medical personnel to evacuate casualties to aid stations and for division medical personnel to collect and evacuate casualties

from aid stations. (See fig. 6.) Ambulances of the collecting company work as far forward as practicable to shorten the litter haul by litter bearers of the collecting company. Collecting company litter bearers may be used to clear the field of casualties behind aid stations whenever aid stations must displace forward before they have time to clear the battlefield of casualties. In emergencies, combat personnel may be specifically detailed to assist in evacuation.

c. Pursuit. In pursuit, the medical personnel with the direct pressure force functions as in the attack. The medical detachment with an encircling force moves by motor when the force moves by motor. When contact is gained, the procedure for an attack is followed.

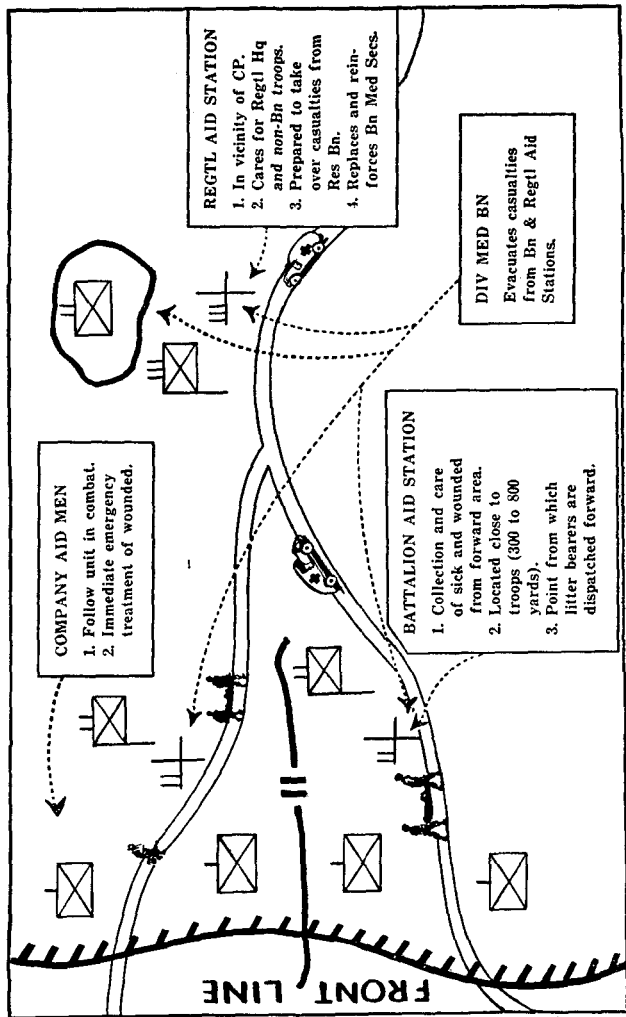

Figure 6. Evacuation of sick and wounded.

42. MEDICAL SERVICE DURING DEFENSE. In a defensive situation, the medical service is usually organized more completely than in an attack. Battalion aid stations are located farther to the rear to prevent overrunning of the site in a local reverse. Battalion aid stations are set up and are improved progressively during the period of occupancy. The regimental aid station usually is established within 300 yards of the regimental command post. Routes of evacuation providing cover for litter bearers are selected and marked. In stabilized situations, company aid posts are established at places near company command posts where the sick and injured may receive emergency treatment and from which litter bearers can evacuate serious cases to the battalion aid station.

43. MEDICAL SERVICE DURING RETROGRADE MOVEMENTS. During a withdrawal, a delaying action, or a retreat, aid stations displace rearward by bounds. Temporary aid stations are set up near the avenues of rearward movement. All available transportation is utilized to evacuate wounded and prevent their capture. The collecting company supporting the regiment may be called upon to furnish reinforcements consisting of litter bearers and/or ambulances. When wounded must be abandoned, a portion of the medical detachment with the necessary supplies is left with them under the protection of the Red Cross flag. The decision to abandon casualties is a command decision.

44. MEDICAL SERVICE OF TRAIN BIVOUACS.

a. One company aid man is attached to the service company. He renders emergency treatment in the train bivouac should the need arise. In addition, Tables of Equipment provide motor vehicles with motor vehicle first-aid kits which contain all the necessary supplies for first-aid procedures.

b. Evacuation will be furnished on call by the nearest medical installations; hence it is the responsibility of the service company commander to locate the nearest medical installation and to establish the quickest means of communication. Medical installations which may be in the vicinity of the train bivouacs include the division clearing station, artillery battalion aid stations, engineer battalion aid stations, or division collecting stations.

45. RELATION OF REGIMENTAL MEDICAL SERVICE TO SUPPORTING MEDICAL ECHELON.

a. Casualties are evacuated from battalion and regimental aid stations by the division medical battalion, which consists of a headquarters detachment and collecting and clearing units.

b. In combat, liaison agents from a collecting company usually join battalion sections of the medical detachment when the battalions move into assembly areas. After battalion aid stations are established, these liaison agents serve to guide litter bearers or ambulances from collecting stations to the aid station. When the aid station displaces, the battalion surgeon notifies the collecting station of the new aid station location by means of these liaison agents.

c. Litter bearers or motor ambulances of the collecting company evacuate casualties from aid stations to division collecting stations. These collecting stations are usually located between 1,200 and 3,000 yards in rear of the front line. At the collecting station, casualties are again sorted.

d. Casualties requiring further evacuation are transported by motor ambulance from the division collecting stations to the division clearing station, some 4 to 7 miles in rear of the front line. In this clearing station, sorting again occurs. Casualties requiring further evacuation from the division area are turned over to a medical unit of a higher echelon for movement to evacuation hospitals. Ordinarily an ambulance unit of the army medical service renders this evacuation service.

46. MEDICAL SERVICE IN CAMP OR BIVOUAC.

In camp or bivouac, the headquarters section of the detachment, or the entire detachment functioning as a unit, may establish a dispensary which operates for the entire regiment. In certain cases, separate battalion dispensaries may be set up within each battalion area. The regimental commander, on recommendation of the regimental surgeon, designates the methods to be used and the hour of sick call. Sick call usually is held immediately after the camp or bivouac is established. Arrangements are made to have men requiring evacuation removed from the regiment by divisional medical units. Prophylactic stations are set up and operated at each dispensary.

Chapter 5

ADMINISTRATIVE PLANS AND ORDERS

47. ADMINISTRATIVE PLANS. The regimental administrative (S-4) plan is prepared by the regimental supply officer. It is based on the orders of higher headquarters, the tactical plan of the regimental commander, and the terrain. (See FM 101-5.) This plan, when approved by the regimental commander, becomes the basis for the issuance of orders to subordinate units and to personnel in the regimental echelon of supply. It includes such of the following matters as are applicable:

a. Rations and water (class I supply). (1) The hour and place at which class I supplies are to be received by the regiment.

(2) The hour and place at which distribution to kitchens begins.

(3) The hour(s) and place(s) at which kitchen vehicles are to be released to subordinate units to deliver supper, breakfast, and cold lunch.

(4) The hour and place at which kitchen vehicles will revert to regimental control after delivery of supper and after delivery of breakfast and cold lunch.

(5) Location of water supply points (if any), and method of procurement and distribution of water.

b. Gasoline and oil (class III supply). (1) Location of supply points.

(2) Time and place of issue to the regiment.

(3) Time, place, and method of distribution to vehicles of subordinate units.

c. Engineer supplies (class IV supply). (1) Location and hour that supply points will be ready to operate.

(2) Time and place tools and fortification materials will be made available to subordinate units; time and place of reversion of empty vehicles to regimental control.

d. Ammunition (class V supply). (1) The location of the ammunition supply point of the next higher unit and its hour of opening.

(2) The time and place of release of ammunition carrying vehicles to subordinate units and the time and place they revert to regimental control.

(3) The issue of extra ammunition (unless decision is left to battalion commanders or is covered in standing operating procedure).

(4) Location of regimental ammunition supply points.

(5) Route of advance of ammunition (in attack only).

(6) Amount and kinds of ammunition to be dumped on position (in defense only).

e. Evacuation. (1) **PERSONNEL.** Location of regimental aid station.

(2) **SALVAGE.** Collection and disposition.

(3) **CAPTURED MATERIEL.** Collection and disposition.

f. Traffic. (1) Traffic priorities prescribed by higher headquarters.

(2) Restrictions (such as permissible daylight traffic and use of lights at night).

(3) Traffic control by military police of higher headquarters.

g. Trains and company transport. (1) Hour and place of release to regimental control, if under control of higher headquarters.

(2) Location of regimental train bivouac, and details pertaining to its defense.

(3) Location of company transport bivouacs, if vehicles are withdrawn to regimental control, and details pertaining to their defense.

(4) Instructions regarding withdrawal of transport from forward areas.

h. Individual rolls. (1) Time and place of release to subordinate units, and designation of vehicles to effect delivery.

(2) Time and place to be assembled by subordinate units for collection by regiment.

NOTE: On the march and during combat, individual rolls may be transported on kitchen and baggage train vehicles when part of their organic loads have been dumped. When the rolls are so transported, they are delivered to units during halts, if the duration of the halt and weather conditions warrant. During offensive combat, rolls are usually sent forward with supper and collected after the serving of breakfast. In defensive situations, troops in forward defensive areas often keep their rolls with them.

48. ADMINISTRATIVE DETAILS IN FIELD ORDERS. a. Any or all of the items of the approved S-4 plan may be included in paragraph 4 of the regimental field order. Usually, however, it is limited to such of the following items as are applicable:

- (1) Location of regimental ammunition supply point.
- (2) Route of advance of ammunition (in attack only).
- (3) Amount of ammunition to be placed on position (in defense only).
- (4) Location of regimental aid station.
- (5) Distribution of fortification materials.
- (6) Traffic restrictions.

(7) Location of regimental train bivouac.

(8) Location of bivouac(s) of company transport, when under regimental control.

b. Elements of the approved S-4 plan that pertain to feeding and to particular units or individuals are usually transmitted orally or by message to those concerned. Ordinarily, this is done after issuance of the regimental field order. In rapidly moving situations, orders relating to administrative matters are issued in fragmentary form.

Part Two
REGIMENTAL SERVICE COMPANY
AND MEDICAL DETACHMENT

Chapter 6

REGIMENTAL SERVICE COMPANY

Section I.

ORGANIZATION OF THE SERVICE COMPANY

49. **COMPOSITION.** The service company of the infantry regiment comprises a company headquarters, a regimental headquarters platoon, and a transportation platoon. (See fig. 7.) For details of organization, equipment, armament, and transport, see current Table of Organization and Equipment.

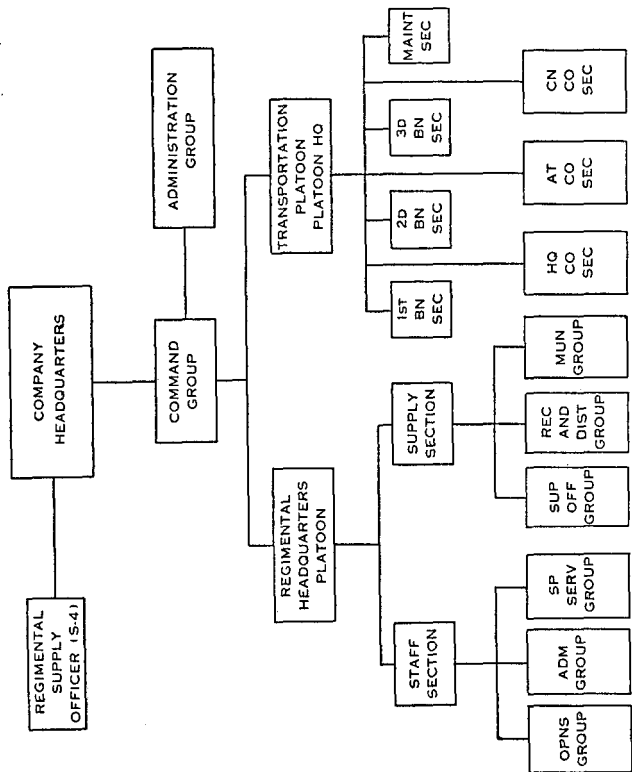

Figure 7. Composition of service company.

50. COMPANY HEADQUARTERS. a. Composition.

Company headquarters includes the regimental supply officer, the assistant supply officer, the company commander, and the personnel necessary to assist the latter in the control and administration of the company. Company headquarters personnel are divided, according to their duties, into two groups—a command group and an administration group.

b. Command group. (1) The command group is composed of the—

(a) Regimental supply officer, S-4.

(b) Company commander.

(c) Warrant officer, supply, administrative.

(d) First sergeant.

(e) Bugler and messenger (who also act as truck drivers).

(2) Principal duties of command group personnel are:

(a) The regimental supply officer supervises the operation of the regimental supply service and is responsible to the regimental commander for its proper functioning. (See par. 4.)

(b) In addition to his duties as company commander, the service company commander assists the regimental supply officer in effecting regimental supply. He is responsible for the discipline, administration, and training of his company. The special training of personnel performing duties under the

supervision of officers not a part of the company is a responsibility of the officers concerned. During marches, the company commander commands the regimental motor column, which consists primarily of regimental trains (less detachments) together with any company transport under regimental control. In combat, he is charged with the establishment, defense, and operation of the regimental train bivouac, and controls all installations and personnel therein. This duty is performed under the supervision of the regimental supply officer when the trains are under regimental control, and under the supervision of a designated representative of the division commander when the regimental trains are under division control.

(c) A warrant officer, supply, administrative, usually functions at the regimental command post and performs such duties as are assigned by the regimental supply officer.

(d) The first sergeant is in charge of enlisted personnel of the command group. He assists the company commander in the interior administration of the company and in the control of its several elements.

(e) The bugler and messenger are trained as observers, truck drivers, and messengers. In combat one accompanies the company commander, the other accompanies the regimental S-4. They assist as directed in observation and control, and perform such other duties as may be assigned.

(3) The transport used by the command group is assigned to company headquarters.

(4) During marches, the company commander and the regimental motor transport officer move at the head of the regimental motor column. During combat, they establish and operate the headquarters of the regimental train bivouac. (See par. 52b(2).)

c. Administration group. (1) The company administration group is composed of personnel whose duties relate primarily to the company mess, supply, personnel administration, and motor vehicle maintenance. It comprises:

(a) Mess sergeant, cooks, and cook's helper.

(b) Supply sergeant, armorer-artificer, and carpenter.

(c) Company clerk.

(d) Truck driver and mechanics.

(e) Basic privates.

(2) The mess sergeant is responsible to the company commander for the training of the cooks and cook's helper and for the operation of the company mess, which is usually established near other company kitchens in the regimental train bivouac.

(3) The supply sergeant is responsible to the company commander for company supply, and is charged with supervising the work performed by the armorer-artificer and the carpenter. In combat, he may be required to supervise the preparation of shelter, facilities, and concealment measures in the regimental train bivouac.

(4) The company clerk performs his duties with the regimental personnel group.

(5) The truck driver and mechanics drive vehicles (other than those driven by the bugler and messenger), which are assigned to company headquarters and perform company maintenance on the organic vehicles of the company.

(6) During marches, the company administration group and the company kitchen and baggage vehicles march with components of the kitchen and baggage train in the regimental motor column. During combat, they usually bivouac and operate in that part of the regimental train bivouac assigned to the kitchen and baggage train.

51. REGIMENTAL HEADQUARTERS PLATOON.

a. Composition. The regimental headquarters platoon consists of a staff section and a supply section.

b. Staff section. (1) The staff section consists of an operations group, an administration group, and a special service group.

(2) The operations group includes the orientation officer, the assistant regimental adjutant (warrant officer), the sergeant major, the operations sergeant, a stenographer, and clerks. It provides the operating personnel for the adjutant (S-1) and the plans and training officer (S-3) at the regimental command post.

(a) The orientation officer, who is also a special service officer, is an assistant to the regimental S-3

and, in addition, is concerned with the training conditions affecting morale, and with orientation and education within the unit.

(b) The assistant regimental adjutant and S-1, a warrant officer, assists the regimental S-1. The sergeant major is S-1's principal enlisted assistant. The sergeant major supervises the delivery of all incoming messages at the regimental command post. (See FM 7-25.) He and one or more clerks prepare the unit journal and other S-1 records under the adjutant's supervision. For duties of S-1, see FM 7-40.

(c) The operations sergeant is the principal enlisted assistant to the regimental S-3. He and one or more clerks perform their duties under the supervision of S-3. For duties of S-3, see FM 7-40.

(3) The administration group consists of the military personnel officer, personnel sergeant, classification specialist, headquarters and record clerks, mail clerks, and chaplain's assistants. Except for the regimental supply service, this group performs all routine administrative and personnel work for the regiment. The company clerks of all companies are grouped under the supervision of the military personnel officer. For duties of the military personnel officer, see FM 7-40. The chaplain's assistants perform the duties prescribed by the chaplains.

(4) The special service group, operating from the location prescribed by the regimental commander, consists of the athletic and recreation officer, special service, who is assistant S-1, and his assist-

ants. The normal duties of this group are supervision of the athletic and recreational activities of the regiment. During combat, members of this group perform such other duties as the regimental commander may direct.

(5) The regimental executive assigns the clerks and messenger(s) of the staff section to S-1, S-3, and the military personnel officer; these assignments are not fixed but are varied from time to time to meet fluctuating conditions at regimental headquarters.

c. Supply section. (1) The supply section is composed of personnel required to operate the regimental supply service in conjunction with the transportation platoon. The section is organized into three groups:

(a) Supply office group.

(b) Receiving and distributing group.

(c) Munitions group.

(2) During field operations, the supply office group and the receiving and distributing group usually operate under the direct supervision of the service company commander.

(3) The supply office group maintains the supply records of the regiment; consolidates and prepares requisitions, records and receipts; compiles reports; and performs such other duties as the regimental supply officer may require. During marches, it usually accompanies the command group of the transportation platoon. In combat, it operates in the regimental train bivouac, except for such clerks as

the regimental supply officer may place at the command post. The group usually comprises a group leader, headquarters clerk(s), stock clerk(s), and messenger(s).

(4) The receiving and distributing group procures all supplies, except ammunition and other class V items, from supply agencies of higher echelons, and sorts, apportions, and issues them to elements of the regiment. It operates the regimental supply points for rations and water (class I); for items authorized by Tables of Organization and Equipment (class II); for gasoline and oil (class III); and on occasions for engineer supplies (class IV). (See pars. 18 and 54.) During marches, this group usually accompanies the command group of the transportation platoon. Additional labor required for handling supplies is furnished from any available personnel in the train bivouac. The group usually comprises a group leader, record clerk(s), and truck driver(s).

(5) The munitions group consists of a munitions officer, munitions warrant officer, and an ammunition sergeant. (See par. 4c.) In general, this group is charged with the operation of the regimental ammunition supply plan, under the supervision of the regimental supply officer. (See par. 47d.) For details pertaining to the functioning of this group, see section V, chapter 2. Transportation for the group is provided by the service company.

(6) For details of supply operations, see chapters 2 and 5.

52. TRANSPORTATION PLATOON. a. Composition. (1) The transportation platoon consists of—

(a) Platoon command group (Platoon headquarters).

(b) Three battalion sections.

(c) Headquarters company section.

(d) Antitank company section.

(e) Cannon company section.

(f) Maintenance section.

(2) The personnel and vehicles of the transportation platoon, together with the medical detachment vehicles and their operating personnel, constitute the regimental trains.

b. Command group. (1) The command group comprises the entire platoon headquarters, consisting of the following personnel:

(a) Platoon leader (regimental motor transport officer).

(b) Second-in-command.

(c) Motor sergeant.

(d) Ammunition sergeant.

(e) Platoon truckmaster.

(f) Truck driver.

(2) The regimental motor transport officer is responsible to the service company commander for the administration, inspection, and training of the platoon; for the mechanical condition of its vehicles;

and for the operation of its components while under regimental control (except such parts of the ammunition train as may be performing their supply mission under command of the munitions officer). In combat, the motor transport officer assists the service company commander in the establishment, defense, and operation of the regimental train bivouac, and assumes control of the bivouac and its elements when the company commander is absent or incapacitated. For detailed duties of unit motor transport officer, see FM 25-10.

(3) The second-in-command assists the motor transport officer in all of his various duties and performs such other tasks as the motor officer may prescribe.

(4) The motor sergeant is the principal enlisted assistant of the regimental motor transport officer.

(5) The ammunition sergeant usually accompanies parts of the ammunition train that are under regimental control, and carries out the orders of the motor transport officer or the munitions officer relative to their operation.

(6) The platoon truckmaster assists in controlling the movement and operation of the regimental trains, usually accompanying parts of the kitchen and baggage train while they are under regimental control.

(7) The truck driver is responsible for the habitual camouflage, concealment, and driver maintenance of his vehicle.

c. Battalion sections. (1) Each battalion section consists of vehicles of the transportation platoon that serve the battalion (h below) and the following personnel:

- (a) Section leader (battalion supply officer).
- (b) Section sergeant (battalion supply sergeant).
- (c) Truckmaster.
- (d) Truck drivers.

(2) The section leader becomes battalion supply officer during periods of tactical training and in operations when the battalion supply echelon is operative. (See par. 3c(2).) When not acting as battalion supply officer, he is responsible to the platoon leader for the training and operation of his section. As battalion supply officer, he commands the ammunition and the kitchen and baggage components of the section (battalion trains) except while they are under regimental control. When his duties require his presence elsewhere, the command of these vehicles may be delegated to the battalion motor transport officer or to an assistant of the battalion supply officer. For his duties as battalion supply officer, see paragraph 5 and FM 7-20.

(3) The section sergeant is the principal enlisted assistant of the section leader. He becomes battalion supply sergeant when the section leader performs the duties of battalion supply officer; as such, he works in the battalion area under supervision of the battalion supply officer. He may be directed to accompany parts of the battalion section of the trains when deemed advisable.

(4) The truckmaster is responsible for the movement of vehicles entrusted to his charge. In periods of tactical training and in operations he usually accompanies the battalion kitchen and baggage train. When vehicles in his charge are under battalion control, he is responsible to the battalion supply officer for their movement; when they are under regimental control, he is responsible to the regimental motor transport officer.

(5) Truck drivers are responsible for the habitual camouflage, concealment, and driver maintenance of their individual vehicles.

d. Headquarters company section. The headquarters company section comprises the truck driver and vehicle of the transportation platoon that serves the headquarters company. (See c(5) above and h(3) below.)

e. Antitank company section. The antitank company section comprises the truck driver and vehicle of the transportation platoon that serves the antitank company. (See c(5) above and h(3) below.)

f. Cannon company section. The cannon company section comprises the truck driver and vehicle of the transportation platoon that serves the cannon company. (See c(5) above and h(3) below.)

g. Maintenance section. (1) The maintenance section consists of the following personnel and equipment:

(a) Warrant officer, motor transport.

(b) Record clerk.

(c) Automobile mechanics (three of whom drive trucks assigned to the section) and a welder.

(d) Trucks carrying tools and portable equipment for second echelon motor maintenance.

(2) For details of motor maintenance operations and functions of this section, see paragraph 31; for detailed duties of motor maintenance personnel, see FM 25-10.

h. Regimental trains. (1) **COMPOSITION.** The regimental train consists of the vehicles and operating personnel of the transportation platoon of the service company and the vehicles and operating personnel of the regimental medical detachment. Regimental trains are classified by function as:

(a) Ammunition train.

(b) Kitchen and baggage train.

(c) Maintenance train.

(d) Medical train.

(2) **AMMUNITION TRAIN.** (a) The ammunition train comprises the train vehicles and operating personnel used to transport ammunition for all units of the regiment. The ammunition train is usually divided into three battalion sections.

(b) Ammunition train vehicles may be allotted to designated units or be pooled. (See par. 21.) While under regimental control, they are commanded by the munitions officer. (See par. 23b.)

(3) **KITCHEN AND BAGGAGE TRAIN.** (a) The kitchen and baggage train comprises the vehicles and operating personnel used to transport rations, water, kitchen equipment, and authorized impedimenta not carried on company transport. Certain company mess and supply personnel usually accompany the kitchen and baggage vehicles that serve their respective companies. The kitchen and baggage train includes one or more cargo trucks and cargo trailers for each company in the regiment.

(b) The vehicles of this train are grouped into six sections, one each, for the three battalions, the antitank company, the cannon company, and the regimental headquarters company. The service company kitchen and baggage vehicles are assigned to company headquarters, but usually operate as part of the train.

(c) The kitchen and baggage train generally moves and bivouacs under regimental (sometimes divisional) control under the command of the regimental motor transport officer. Elements are released to subordinate units as necessary. (See pars. 2, 8, and 9.)

(4) **MAINTENANCE TRAIN.** The maintenance train comprises the vehicles and operating personnel of the maintenance section, transportation platoon of the service company. For maintenance operations, see paragraph 31.

(5) **MEDICAL TRAIN.** The medical train transports medical supplies and certain medical personnel. For operation, see chapter 7.

(6) DESIGNATION OF TRAINS. (a) Trains may be designated by unit as—

1. 1st Infantry trains, denoting that portion of the regimental transportation, including personnel, operating under the immediate orders of the regimental commander primarily for supply, evacuation, and maintenance.
2. Trains, 1st Battalion, 1st Infantry, denoting ammunition and kitchen and baggage vehicles and personnel of the transportation platoon allotted to the 1st Battalion section, together with any attached medical vehicles and operating personnel.

(b) Trains may also be designated by unit and function as—

1. Ammunition train, 1st Infantry.
2. Ammunition train, 1st Battalion, 1st Infantry, denoting ammunition components of the 1st Battalion section.
3. Kitchen and baggage train, 1st Battalion, 1st Infantry, denoting kitchen and baggage components of 1st Battalion section.

(7) SECURITY OF TRAINS IN MOVEMENT.

(a) The close-in protection of trains in movement is provided by the officer in charge, usually under the supervision of the supply officer of the unit controlling the movement. Plans should include adoption of that type of motor movement which offers

the best protection from attack and still affords adequate control and maintenance of direction. Standing operating procedure should be such as will insure that the vehicles will get through to their destination, and should include a prohibition against halting the column unless so ordered by competent authority. One or more guards should accompany each vehicle to man individual weapons and those mounted on vehicles. All guards should be on the alert to give warning of impending air, ground, or chemical attack.

(b) When the situation indicates that available personnel is insufficient to provide adequate security, a specific request should be made for such reinforcements (including transportation) as are necessary.

i. Marches. (1) During a route march, the transportation platoon, less sections released to subordinate units, comprises a part of the regimental motor column, which usually moves by bounds in rear of the foot elements of the main body. (See par. 24.) Vehicles of the ammunition train usually precede other components of the platoon and travel in the order in which they will probably be released.

(2) The maintenance section marches at the rear of the motor column, prepared to repair or tow un-serviceable repairable vehicles.

j. Combat. For conduct of the transportation platoon in combat, see chapters 2 and 3.

53. TRAINING. The enlisted personnel of the service company are trained to—

a. Perform the basic duties of all infantry soldiers, particularly in the use of the weapons with which they are armed and in the proper methods of caring for themselves in the field.

b. Perform their specific duties in the service company. Basic privates are trained as replacements.

Section II.

OPERATION OF THE SERVICE COMPANY

54. GENERAL FUNCTIONS. a. The service company is primarily the regimental supply unit. (See ch. 2.) It performs the following general functions:

(1) Furnishes the following part of the enlisted personnel for regimental headquarters: a personnel group; the operations and training section; the supply section; and assistants for the athletic and recreation officer and the chaplains.

(2) Receives and distributes all supplies.

(3) Performs second echelon motor maintenance which cannot be performed by the other companies of the regiment.

(4) Furnishes supply transportation and personnel for battalions and separate companies of the regiment.

b. Incident to a(2), (3), and (4) above, the service company establishes, operates, and controls in combat—

(1) Regimental supply points for—

(a) Rations and water (class I supply).

(b) Gasoline and oil (class III supply).

(c) Engineer supplies (class IV supply).

(d) Ammunition (class V supply).

(2) The regimental train bivouac (area of regimental rear echelon elements), usually containing—

(a) Regimental supply officer's (S-4's) section, less personnel at the regimental command post.

(b) Service company headquarters (bivouac headquarters).

(c) The transportation platoon, including the—

1. Command group (platoon headquarters).

2. Maintenance section.

3. Ammunition train (in defensive situations).

4. Kitchen and baggage train (when under regimental control).

(d) Mess and supply personnel and kitchens of all companies when not required in forward area (usually operate in the bivouac of kitchen and baggage train).

(e) Regimental ration (class I) supply point (usually near kitchen locations).

(f) Regimental gasoline and oil (class III) supply point.

55. PROCUREMENT AND DISTRIBUTION OF SUPPLIES. For the duties and activities of service company personnel in this connection, see paragraphs 4, 5, and 51.

56. MOTOR MAINTENANCE. For duties and activities of the company pertaining to motor maintenance, see paragraph 31.

57. REGIMENTAL TRAIN BIVOUAC. a. General.

(1) The regimental trains, less components released to battalion control, are bivouacked during combat under control of the regimental or higher commander, and under the direct command of the service company commander, or under an officer, usually the motor transport officer, to whom the command may be temporarily delegated by the latter. When not being used for supply, evacuation, or maintenance, vehicles comprising the trains are concealed in the regimental train bivouac.

(2) The regimental train bivouac usually contains, in addition to trains, various administrative installations and personnel. For interior arrangement of the train bivouac, see c below.

(3) The *general* location of the regimental train bivouac is usually announced by higher headquarters; occasionally this location is based on recommendations of the regimental commander. Knowing the general location of the regimental train bivouac, the regimental supply officer consults the service company commander and frequently the regimental motor transport officer concerning the *exact* location which he recommends for approval by the regimental commander.

(4) During rapidly moving situations, the regimental train bivouac may be merely a temporary assembly area for trains and administrative personnel.

(5) The size of the area required for the bivouac may vary from approximately $\frac{1}{4}$ square mile to 1 or 2 square miles, depending primarily on the concealment afforded, the road net, and the features favoring defense against air and mechanized attack.

(6) The regimental train bivouac and the installations and personnel in the bivouac are commanded by the service company commander. (See par. 50b (2) (b).)

b. Characteristics. The following characteristics are sought in selecting an area for the regimental train bivouac:

(1) Location beyond the mass of probable hostile light artillery fires.

(2) Accessibility to roads leading to forward troop locations as well as to the rear.

(3) Concealment from hostile air and ground observation.

(4) Sufficient size to permit dispersion of vehicles and activities.

(5) Suitable standing and turn arounds for motor vehicles.

(6) Features favoring defense against air and mechanized attack.

(7) Location causing no interference with friendly troop movements.

(8) Location forward of any barrier that may become impassable for motor transportation.

(9) Water (and fuel, if wood ranges are in use).

(10) Buildings usable as shelter for supply and maintenance activities.

c. Interior arrangement. The bivouac area is divided into subareas by the service company commander, usually with the assistance of the regimental motor transport officer. (See fig. 8.) Division into the following subareas is usually appropriate:

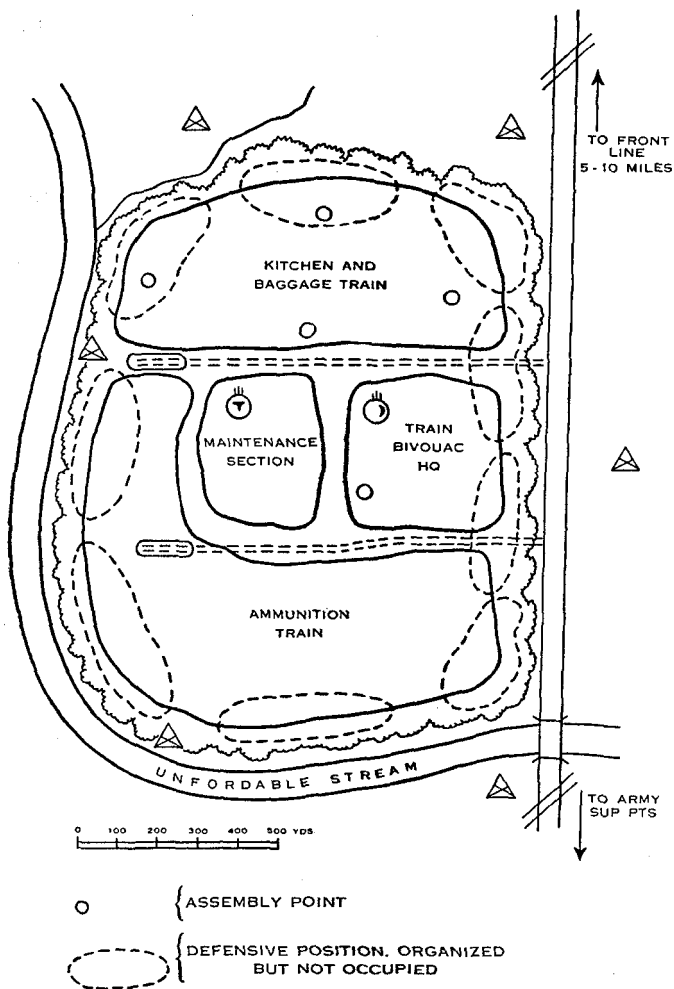

Figure 8. Regimental train bivouac—schematic. Interior arrangement and measures for close-in security.

(1) Kitchen and baggage train bivouac, containing—

(a) Components of kitchen and baggage train.

(b) Company kitchen locations.

(c) Mess and supply personnel of all companies of the regiment.

(2) Ammunition train bivouac, containing all components of the ammunition train when they are not actually performing their supply mission or released to subordinate units.

(3) Maintenance section area.

(4) Train bivouac headquarters area, usually containing—

(a) Service company headquarters.

(b) Regimental supply officer's (S-4's) section.

(c) Receiving and distributing group of supply section; ration supply point (near kitchen locations); and gasoline and oil supply point (accessible to vehicles).

d. Signal communication. Rapid means of signal communication are required between the regimental command post and the regimental train bivouac, and also between the regimental train bivouac and division headquarters. Radio (special purpose net), motor messengers, and wire communication (when practicable), are the means ordinarily used. Motor and dismounted messengers usually provide ade-

quate communication within the bivouac; in defensive situations, wire communication may be established between subareas within the bivouac.

e. Security. (1) Security for the regimental train bivouac is provided by means of an area defense and a close-in defense. The division commander is responsible for the area defense of the entire division rear area. Close-in defense is the responsibility of the troops occupying the bivouac.

(2) The regimental commander is responsible for the security of all supply installations operating under his control. He usually charges the service company commander, under the general supervision of the regimental S-4, with the close-in defense of the train bivouac. (See par. 50b(2)(b).) The S-4, assisted by the service company commander, prepares the plan for such defense and integrates it with the plan for area defense established by higher headquarters. Primarily, such plan will be based on the troops and weapons available within the bivouac but when the need for additional security is indicated, S-4 specifically recommends to the regimental commander the types and number of reinforcements required. Upon approval of the plan by the regimental commander, the service company commander is charged with the detailed execution.

(3) When the trains of a battalion are bivouacked at a distance from the other trains of the regiment, the battalion S-4 provides for their security in the manner described above for the regimental S-4 and service company commander.

(4) Administrative troops are trained in the use of individual weapons, as well as those weapons mounted on vehicles of their units. They are also trained in the tactics and technique of small infantry units and impressed with the fact that they are combat troops and must be able to function as such. The personnel available to the service company commander for protection of the train bivouac will vary because of the absence from the area at times of personnel on supply and service activities. The maximum strength will include the personnel of the service company (less the staff section of regimental headquarters platoon) and the rear echelon of company headquarters of all companies of the regiment, plus drivers of company transport whose vehicles are in the bivouac area. Weapons include rifles, carbines, antitank and fragmentation grenades, antitank rocket launchers, and caliber .50 machine guns.

(5) In preparing plans for the close-in defense of the train bivouac, consideration should be given to both passive and active means and to the several methods for defense that may be adapted to fit the existing circumstances. Some of the means and methods to be considered and integrated into the defense plan are:

(a) *Concealment* as some protection from all types of attack.

(b) *Dispersion* of vehicles, personnel, and installations.

(c) *Natural obstacles* as protection against mechanized attack.

(d) *Artificial obstacles*, such as mines, demolitions, and other devices, to provide protection against mechanized attack.

(e) *Warning devices*, such as trip flares and noise-makers, designed to give warning of the approach of an enemy.

(f) *Warning system*, including observation posts, listening posts, patrols, and alarm system, to give warning of air, airborne, mechanized, or ground attack.

(g) *Interior guard* to maintain discipline, sound alarm in case of gas attack, and give warning of enemy who have eliminated or eluded the outer observation posts.

(h) *Organization* of available personnel and weapons into combat groups to facilitate control.

(i) Designation of *assembly points* where combat groups may assemble upon warning of an attack.

(j) *Foxholes* for all personnel, sited for close-in defense of vehicles, close-in defense of installations, and for the perimeter defense.

(k) *Individual defense* can best be accomplished from the foxhole each individual prepares near his work site.

(l) *Vehicular defense* is the duty of the driver and may frequently be conducted from a foxhole in

the vicinity of the vehicle. In any type of defense the driver should be trained to defend his vehicle in this manner.

(m) *Perimeter defense* (fig. 8) is executed by having combat groups occupy previously selected defensive positions in the direction from which the attack threatens. Drivers remain near their vehicles in order to defend them. The defensive positions are selected along the perimeter in order to provide all-around defense of the train bivouac and should be mutually supporting.

(6) (a) Daylight attacks of which advance warning has been given can, in many instances, best be repulsed by using the perimeter defense referred to above.

(b) Night attacks and daylight surprise attacks can, in most instances, best be repulsed by using the individual and vehicular defense referred to above.

(7) Standing operating procedure for the close-in defense of the train bivouac, which is within the capabilities of the troops available at that installation, should include those means and methods discussed in (5) above which are applicable to most situations. Such standing operating procedure is then the basis for the complete plan for close-in defense of the train bivouac in each particular situation.

Chapter 7

ORGANIZATION OF THE REGIMENTAL MEDICAL DETACHMENT

58. REFERENCES. For details of composition and equipment of the medical detachment, infantry regiment, see Table of Organization and Equipment. For medical service and evacuation within the regiment, see chapter 4.

59. GENERAL. The medical detachment of the infantry regiment consists of a headquarters section, and three identical battalion sections. (See fig. 9.) During combat, each battalion section normally serves its designated battalion; however, with the approval of the regimental commander, the regimental surgeon may reinforce any one section by assigning men from another section.

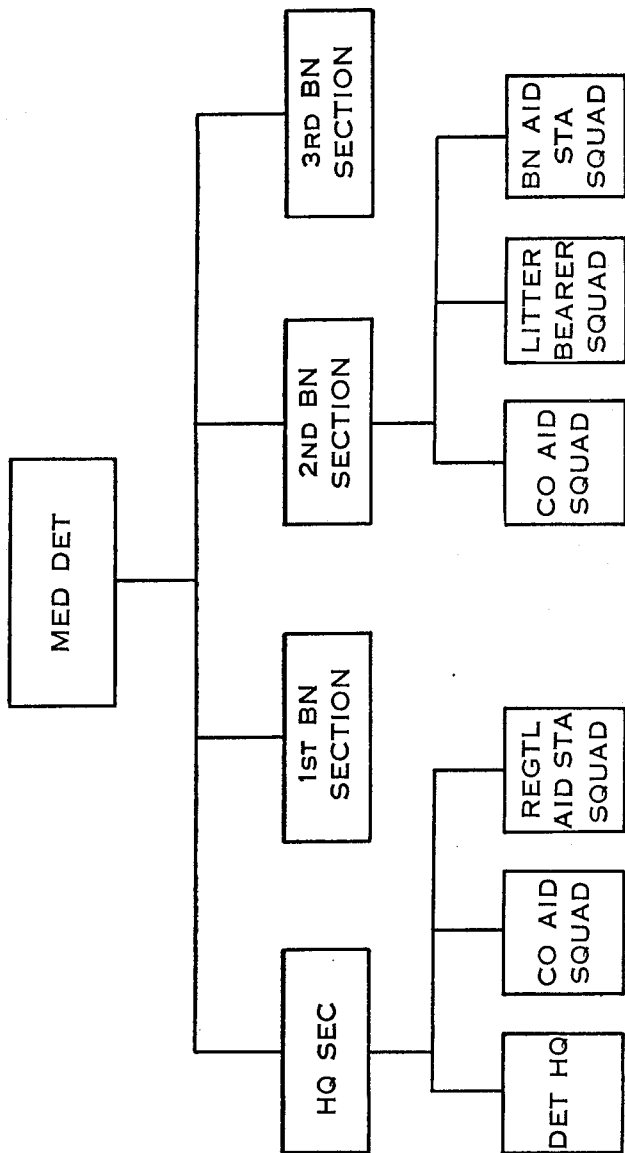

Figure 9. Composition of regimental medical detachment.

60. HEADQUARTERS SECTION. The headquarters section is divided into a detachment headquarters, a regimental aid station squad, and a company aid squad.

a. Detachment headquarters. The detachment headquarters includes the regimental surgeon, a non-commissioned officer who acts as first sergeant, and a record clerk.

(1) The senior medical officer present with the regiment commands the medical detachment and is regimental surgeon. He serves as a special staff officer on the regimental commander's staff, and confers with other members of the staff on tactical and administrative matters.

(a) The regimental surgeon performs the following duties:

1. Organizes the medical detachment and assigns personnel to the several sections.
2. Conducts as much of the training of the detachment as is not given in conjunction with the training of combat elements of the regiment.
3. Supervises the instruction of the regiment in personal hygiene, field sanitation, first aid, and malaria control.
4. Makes medical and sanitary inspections, and keeps the regimental commander informed of the medical situation or status in the regiment.

5. Supervises the establishment and operation of the regimental dispensary, and the operation of battalion dispensaries.
6. Is responsible for the supply of the detachment and requisition for necessary medical and dental supplies and equipment. For procedure, see FM 8-10.
7. Keeps all records and renders all reports that are required.
8. Personally assists in the care and treatment of casualties and performs such other duties as the regimental commander may require.

(b) During combat or when combat is imminent, the surgeon recommends the site for the regimental aid station and the routes of evacuation. He makes a medical estimate of the situation and prepares the medical plan, which he submits to the regimental commander through S-4. When necessary, he asks for additional personnel to serve as litter bearers. He makes arrangements with the division surgeon for the evacuation of aid stations and keeps him informed of the tactical situation within the regiment. He checks on the status of medical supplies in all units of the regiment and takes steps to insure timely replenishment.

(c) During combat, the surgeon supervises the collection and evacuation of wounded. He keeps himself informed of the tactical situation and takes measures to provide replacements or reinforcements of medical personnel and replenishment of

supplies. He secures assistance, when necessary and practicable, from the division medical battalion. He keeps the division medical battalion informed of the tactical situation in the regiment.

(d) When an infantry battalion is to undertake a special mission, the surgeon can clear the battalion of wounded by having the regimental aid station move to its vicinity, or by requesting priority evacuation of its aid station.

(e) The surgeon also supervises the preparation of casualty lists and other required records. One copy of each casualty list is sent to the regimental commander and one to the division surgeon. For details of the functions of the regimental surgeon, see FM 8-10.

(2) **ACTING FIRST SERGEANT.** The noncommissioned officer who acts as first sergeant establishes and operates the detachment command post under the supervision of the regimental surgeon. He assists the regimental surgeon in maintaining contact with the regimental command post and the battalion aid stations, performs the interior administration of the detachment, and is responsible for the operation of the detachment message center.

(3) **RECORD CLERK.** The record clerk maintains records of the sick and wounded, assists the acting first sergeant in the interior administration of the detachment and operation of the command post and message center, drives a vehicle of the detachment headquarters, and is responsible for its driver maintenance.

b. Regimental aid station squad. The regimental aid station squad includes the assistant regimental surgeon, the regimental dental surgeon, the assistant regimental dental surgeon, a medical sergeant (acting detachment supply sergeant), a podiatrist, a sanitary technician, and dental, surgical, and medical technicians, a truck driver, and basic privates.

(1) **ASSISTANT REGIMENTAL SURGEON.** The assistant regimental surgeon establishes and operates the regimental aid station assisted by the regimental and assistant regimental dental surgeons. He can be used by the regimental surgeon as a replacement for medical officers who become casualties in the battalion sections or to augment one of the battalion sections.

(2) **REGIMENTAL DENTAL SURGEON.** The regimental dental surgeon assisted by the assistant regimental dental surgeon operates the dental service. Both dental officers are trained in first aid, emergency care and treatment of the sick and wounded, and operation of the aid station, and can be used as replacements for medical officers of the regiment.

(3) **MEDICAL SERGEANT.** The medical sergeant is in charge of the enlisted personnel of the regimental aid station squad. He also acts as the detachment supply sergeant; as such, his duties include the replenishment and distribution of detachment supplies. He procures and distributes medical supplies as directed by the regimental surgeon. (See par. 62b.) He keeps the regimental surgeon informed of the supply needs of the detachment.

(4) **PODIATRIST.** The podiatrist is an enlisted specialist chiefly concerned with the care of feet. Under direction of the regimental surgeon, he instructs personnel of the regiment in hygiene of the feet, and is especially trained in treating minor foot ailments.

(5) **SANITARY TECHNICIAN.** The sanitary technician is especially trained to assist the regimental surgeon in making routine sanitary inspections in the regiment.

(6) **DENTAL, SURGICAL, AND MEDICAL TECHNICIANS.** The dental, surgical, and medical technicians perform technical tasks as indicated by their designations, drive and maintain the section vehicles, and perform such other duties as may be directed.

c. Company aid squad. The company aid squad of the headquarters section furnishes company aid men for attachment to the antitank company, cannon company, regimental headquarters and headquarters company, and service company. Company aid men are equipped with pouches containing first-aid packets, bandages, emergency medical tags, and other items for the administration of emergency treatment. Their duties are to—

(1) Maintain contact with the company to which they are assigned.

(2) Forward information to their section surgeons by litter bearers or walking wounded as to the

location of units to which assigned, any contemplated changes in location or disposition, and the location and number of casualties.

(3) Administer emergency treatment.

(4) Instruct sick and wounded as to the exact location of the aid station and the route thereto.

(5) Place seriously sick and wounded in sheltered locations on the route of advance of the company which they serve.

(6) Examine, tag, and mark the location of the dead.

61. BATTALION MEDICAL SECTIONS. The three battalion sections of the detachment are identical in organization and functions. Each section is divided into a battalion aid station squad, a company aid squad, and a litter bearer squad.

a. Aid station squad. The aid station squad includes the battalion surgeon and the medical assistant, MAC, a section sergeant, a medical corporal, and medical and surgical technicians.

(1) **BATTALION SURGEON.** The medical officer in each battalion section is the battalion surgeon. He is assisted by a Medical Administrative Corps officer, the medical assistant, MAC. The battalion surgeon's staff duties within the battalion correspond to those of the regimental surgeon within the regiment. His command duties are not so extensive. His duties in combat are to—

(a) Reconnoiter for possible aid station sites and prepare a medical plan based on the tactical plan of the battalion.

(b) Dispose the battalion medical section in the most appropriate manner.

(c) Establish the aid station, supervise its operation, and personally assist in the care and treatment of casualties.

(d) Supervise the operation of the litter squad.

(e) Keep in contact with the battalion commander and his future plans and project his own plan to correspond.

(f) Keep the commander informed of the situation with respect to sick and wounded and make appropriate and timely recommendations.

(g) Send back information to the regimental surgeon and the division medical unit, and make appropriate requests for support, additional supplies and equipment, or for evacuation of casualties.

(h) Perform such other duties as the battalion commander may require.

(2) SECTION SERGEANT. The section sergeant is in charge of the enlisted personnel of the section, is the section supply sergeant, and assists in the care of casualties.

(3) MEDICAL CORPORAL. The medical corporal has charge of the sterilization of instruments, administers hypodermic medication, and otherwise assists in the care and treatment of casualties.

(4) **MEDICAL AND SURGICAL TECHNICIANS.** The medical and surgical technicians perform tasks relating to the care and treatment of casualties.

(5) **OPERATION.** The battalion aid station operates and functions the same as the regimental aid station. (See par. 60b.)

b. Company aid squad. The company aid squad of each battalion section furnishes three company aid men for attachment to each rifle company (one per rifle platoon), and one to each platoon of the heavy weapons company. Their duties are similar to those of the company aid men in the headquarters section. (See par. 60c.)

c. Litter bearer squad. Litter bearers carry the wounded who are unable to walk to the battalion aid station, where aid station personnel administer further treatment. They usually operate in teams of four men, since the work is very fatiguing. The vehicles of the section are utilized to assist in this work in those areas comparatively free from aimed small-arms fire. They evacuate the wounded, not only of their assigned battalion, but also of any other units in the battalion zone or sector.

62. EQUIPMENT AND SUPPLY. a. The medical equipment and supplies of the detachment are packed in various standard chests in the headquarters section and in unit packs and a standard chest in each battalion section, and are carried in the detachment trucks and trailers. The vehicles are known

collectively as the regimental medical train. These supplies are adequate for the essential treatment of the command for approximately one day of combat.

b. The regimental surgeon is responsible for the medical supply of the detachment. Routine medical supply is effected by requisition on the division medical supply officer through the regimental supply officer. During combat the regimental surgeon or battalion surgeons may make informal requests to the division medical unit (collecting company) in direct support. This unit will send supplies forward by litter bearers or ambulance. Items such as litters, blankets, and splints, which accompany evacuated casualties to the rear, are replaced automatically. When the ambulances or bearers from the division unit return to the regiment, they bring with them items of equipment corresponding to the ones taken out on the previous trip. For details of medical supply, see FM 8-10.

63. TRAINING. For details of training of the regimental medical detachment, see FM 8-10 and MTP 8-101.

Appendix I

LIST OF REFERENCES

Rifle Company, Infantry Regiment	FM 7-10
Heavy Weapons Company, Rifle Regiment	FM 7-15
Rifle Battalion	FM 7-20
Headquarters Company, Intelligence and Signal Communication, Rifle Regiment	FM 7-25
Antitank Company, Infantry Regiment and Anti- tank Platoon, Infantry Battalion	FM 7-35
Cannon Company, Infantry Regiment	FM 7-37
Rifle Regiment	FM 7-40
Mobile Units of the Medical Department	FM 8-5
Medical Service of Field Units	FM 8-10
Field Sanitation	FM 8-40
Records of Morbidity and Mortality (Sick and Wounded)	FM 8-45
Bandaging and Splinting	FM 8-50
Reference Data	FM 8-55
Military Sanitation and First Aid	FM 21-10
Signal Communication	FM 24-5
Motor Transport	FM 25-10
Operations	FM 100-5
Administration	FM 100-10

Appendix I (Cont'd)

The Staff and Combat Orders	FM 101-5
Organization, Technical and Logistical Data	FM 101-10
Organization and Training	MR 3-1
Medical Department Soldier's Handbook	TM 8-220
Motor Vehicle Inspections and Preventive Maintenance Services	TM 9-2810
Motor Vehicles	AR 850-15

Appendix II FORM FOR BREAK-DOWN OF RATINGS

Sheet No. Date

No. of Sheets Bill of Fare No.

Allow 100 men	15	70	3	5	60	12	10	17	2	4	3	1	10	2	12	12	3	10	Strength																																			
																				Bacon	Potatoes, Irish	Beans, String No. 10 Can	Beef, Corned No. 6 Can	Bread	Cheese, American	Coffee	Eggs	Flour, Wheat	Jam, Peach No. 2	Lard, Substitute	Mayonnais	Milk, Evap.	Onions	Peaches, No. 2½ Can	Pineapple, No. 2½ Can	Pork, Lunch Meat, No. 6 Can	Sugar, Granulated																	
UNIT	lb.	lb.	can	can	lb.	lb.	lb.	doz	lb.	jar	lb.	jar	can	lb.	can	can	can	lb.																																				
HQ CO	125	19	88	4	6	75	15	13	21	2	5	4	1	13	2	15	15	4	13																																			
SERV CO	108	16	76	3	5	65	13	11	18	2	4	3	1	11	2	13	13	3	11																																			
AT CO	152	23	106	5	7	91	18	15	26	3	6	5	2	15	3	18	18	5	15																																			

CN CO	112	17	79	3	6	67	13	11	19	2	4	3	1	11	2	13	13	3	11
BN HQ																			
1st BN	152	23	106	5	8	91	18	15	26	3	6	5	2	15	3	18	18	5	15
A CO	181	27	127	5	9	109	22	18	31	4	7	5	2	18	4	22	22	5	18
B CO	178	27	125	5	9	107	21	18	30	4	7	5	2	18	4	21	21	5	18
C CO	165	25	116	5	8	99	20	17	28	3	6	5	2	17	3	20	20	5	17
D CO	155	22	108	5	8	93	19	15	26	3	6	5	2	15	3	19	19	5	15
BN HQ																			
2d BN	148	22	104	4	7	89	18	15	25	3	6	4	1	15	3	18	18	4	15
E CO	176	26	123	5	9	106	21	18	30	3	7	5	2	18	3	21	21	5	18
F CO	177	27	124	5	9	106	21	18	30	3	7	5	2	18	3	21	21	5	18
G CO	185	28	130	6	9	111	22	19	31	4	7	6	2	19	4	22	22	6	19
H CO	146	22	102	4	7	88	18	15	25	3	6	4	1	15	3	18	18	4	15
BN HQ																			
3d BN	151	23	106	5	8	91	18	15	26	3	6	5	2	15	3	18	18	5	15
I CO	158	24	111	5	8	85	19	16	27	3	6	5	2	16	3	19	19	5	16
K CO	170	26	119	5	9	102	20	17	29	3	7	5	2	17	3	20	20	5	17
L CO	188	28	132	6	9	123	23	19	32	4	8	6	2	19	4	23	23	6	19
M CO	153	23	107	5	8	92	18	15	26	3	6	5	2	15	3	18	18	5	15
TOTAL	2,980	448	2,089	90	149	1,790	357	300	506	58	117	90	33	300	58	357	357	90	300
AMT ACTUALLY RECD FROM Q.M.	450		2,100	90	144	1,800	360	300	510	50	120	90	36	288	50	360	360	90	300

NOTE. Strengths based on probability of losses (casualties, absentees). Personnel of Medical Detachment included in regimental headquarters and battalion headquarters company totals.

Appendix III

MOTOR MAINTENANCE— ECHELONS OF MAINTENANCE

MAINTENANCE BY OPERATING ORGANIZATIONS

First echelon (driver)	Second echelon (company)
<p>(1) Responsibility rests on— Unit commander.</p> <p>(2) Performed by— Driver, operator, or crew.</p> <p style="padding-left: 20px;">(a) Preventive maintenance.</p> <p style="padding-left: 40px;">(b) Servicing.</p> <p style="padding-left: 40px;">(c) Lubrication.</p> <p style="padding-left: 40px;">(d) Care of tools, equipment, tires, batteries.</p> <p style="padding-left: 40px;">(e) Emergency roadside repairs (see FM 25-10, FM 17-5, appropriate TM for the vehicle).</p>	<p>(1) Responsibility rests on— Unit commander.</p> <p>(2) Performed by—</p> <p style="padding-left: 20px;">(a) Companies and detachments with maintenance personnel authorized.</p> <ol style="list-style-type: none"> 1. Fifty mile run-in test prior to organizational use (or specified in appropriate TM). Technical advice to command echelon in supervision of first echelon maintenance. 2. Lubrication. 3. Scheduled maintenance services, monthly, and as designated in TM 9-2810 and other appropriate TM's. 4. Minor repair and minor unit replacement (see appropriate TM). 5. Supply. 6. Battlefield recovery. 7. Overflow work from lower echelon. <p style="padding-left: 20px;">(b) Battalions, squadrons, regiments and separate companies and detachments.</p> <ol style="list-style-type: none"> 1. Maintenance to include as a minimum, the operator in (a) above, not performed by the company. 2. Technical advice to command echelon in supervision of company maintenance. 3. Scheduled maintenance services, semiannually and as designated in TM 9-2810 and other appropriate TM's. 4. Limited unit replacement. 5. Battlefield recovery.

Appendix III—(Cont'd)

MAINTENANCE BY TECHNICAL SERVICE MAINTENANCE UNITS

Third echelon (medium)	Fourth echelon (heavy)	Fifth echelon (base shop)
<p>(1) Responsibility rests on—</p> <p style="padding-left: 20px;">Commander of tactical or administrative unit having jurisdiction over the unit or installation concerned.</p> <p>(2) Performed by—</p> <p style="padding-left: 20px;">Light and medium maintenance units, including post and port shops.</p> <p style="padding-left: 20px;">(a) Technical advice to command echelon in supervising organizational maintenance.</p> <p style="padding-left: 20px;">(b) Overflow work from lower echelons. Repair of accessory assemblies. See appropriate TM's.</p> <p style="padding-left: 20px;">(c) Supply.</p> <p style="padding-left: 20px;">(d) Battlefield recovery (supporting using arms).</p> <p style="padding-left: 20px;">(e) Evacuation.</p>	<p>(1) Responsibility rests on—</p> <p style="padding-left: 20px;">Commander of tactical or administrative unit having jurisdiction over the unit or installation concerned.</p> <p>(2) Performed by—</p> <p style="padding-left: 20px;">Heavy maintenance and field depot units, including designated post and service command shops.</p> <p style="padding-left: 20px;">(a) Technical advice to command echelon in supervision of organizational maintenance.¹</p> <p style="padding-left: 20px;">(b) Overflow from lower echelons, including vehicle replacement.</p> <p style="padding-left: 20px;">(c) Repair of units, assemblies and subassemblies as designated in appropriate TM's.</p> <p style="padding-left: 20px;">(d) Vehicle rebuild from serviceable assemblies and subassemblies.</p> <p style="padding-left: 20px;">(e) Vehicle assembly and salvage.</p> <p style="padding-left: 20px;">(f) Emergency fifth echelon repair in units designated by the War Department.²</p> <p style="padding-left: 20px;">(g) Supply.</p> <p style="padding-left: 20px;">(h) Battlefield recovery (supporting using arms).</p> <p style="padding-left: 20px;">(i) Evacuation.</p>	<p>(1) Responsibility rests on—</p> <p style="padding-left: 20px;">Chief of technical service or theater or base commander.</p> <p>(2) Performed by—</p> <p style="padding-left: 20px;">Base units.</p> <p style="padding-left: 20px;">(a) Overflow from lower echelons, including vehicle replacement.</p> <p style="padding-left: 20px;">(b) Rebuild of major unit assemblies, accessory unit assemblies and subassemblies.</p> <p style="padding-left: 20px;">(c) Vehicle assembly and parts reclamation and salvage.</p>

¹ The chief of technical service concerned will give technical advice and supervision to service command shops. Service command shops will not perform fifth echelon (base shop) operations unless expressly authorized by the chief of service concerned.

² Dismantling of major unit assemblies will not be undertaken in the continental United States except by units designated by War Department.

INDEX

	<i>Paragraphs</i>	<i>Pages</i>
Administration	1, 3	1, 3
Administrative:		
Orders	1, 2, 4, 7, 48	1, 7, 14, 86
Plans	10, 47	21, 83
Advance guard:		
Ammunition supply during	24	44
Medical service for	39	73
Aid station:		
Battalion	38, 61	69, 126
Composition	38, 60, 61	69, 121, 126
Displacement	41, 45	76, 81
Functions	38	69
Personnel	60, 61	121, 126
Procedure	38, 41, 45	69, 76, 81
Regimental	38, 60	69, 121
Site, characteristics of	38	69
Ammunition: (<i>See also</i> Supply, class V.)		
Bearers	21	38
Destruction of	34	62
Records (reports)	22	39
Sergeant, service company	52	99
Supply. (<i>See</i> Supply, class V.)		
Train	24, 52	44, 99
Ammunition and pioneer platoon.....	5, 26	10, 45
Antitank ammunition supply. (<i>See</i> Supply, class V.)		
Approach march:		
Ammunition supply during	25	44
Medical service during	40	75
Arms. (<i>See</i> weapons.)		
Assembly area, medical service in.....	40	75
Athletic and recreation officer.....	51	95
Attached elements, supply of.....	3	3
Attack:		
Ammunition supply during	26	45
Medical service during	41	76
Automobile mechanic	31, 52	56, 99

INDEX (Continued)

	<i>Paragraphs</i>	<i>Pages</i>
Basic principles of supply.....	3	3
Battalion:		
Aid station. (See Aid station.)		
Ammunition and pioneer platoon.....	5, 13, 26	10, 31, 45
Ammunition supply point	26	45
Ammunition train	26	45
Motor transport officer	5, 25, 26, 31	10, 44, 45, 56
Release point	2, 10	1, 21
Sections, medical detachment	61	126
Supply officer	5, 10, 23, 25, 26, 52	10, 21, 40, 44, 45, 99
Supply sergeant	26	45
Surgeon	39-41, 61	73, 126
Surgeon, assistant	39, 61	73, 126
Cannon company, ammunition supply. (See Supply, class V.)		
Captured supplies	21, 32	38, 60
Casualty lists	60	121
Chemicals. (See Supply, class V.)		
Chlorination of water	11	26
Class I supply. (See Supply, class I.)		
Class II supply. (See Supply, class II.)		
Class III supply. (See Supply, class III.)		
Class IV supply. (See Supply, class IV.)		
Class V supply. (See Supply, class V.)		
Clearing station	2, 36, 45	1, 68, 81
Clothing. (See Supply, class II.)		
Collecting:		
Company	39, 45	73, 81
Station	2, 36, 45	1, 68, 81
Company:		
Aid men	39-41, 44, 60, 61	73, 81, 121, 126
Ammunition supply. (See Supply, class V.)		
Commander, supply duties of.....	4, 6, 10, 26, 31	7, 13, 21, 45, 56
Mess location	10	21

INDEX (Continued)

	<i>Paragraphs</i>	<i>Pages</i>
Daily strength report	8	17
Data, logistical	1	1
Defense:		
Ammunition supply during	28	52
Medical service during	42	80
Of train bivouac	57	110
Delaying action, medical service during.....	43	80
Dental surgeon	60	121
Destruction of vehicles and other materiel	34	62
Development, medical service during.....	41	76
Dispensary (<i>see also</i> Regimental dispensary; Battalion dispensary)	4	7
Division:		
Clearing station	2, 45	1, 81
Collecting station	2, 36, 45	1, 68, 81
Engineer supply point	13, 19	31, 36
G-4	4, 12	7, 30
Medical:		
Battalion	39, 45	73, 81
Supply point	14	31
Ordnance office	22	39
Signal supply point	20	37
Water supply point	11	26
Duties of:		
Battalion:		
Motor transport officer	5, 25, 26, 31	10, 44, 45, 56
Supply officer	5, 10, 23, 25, 26, 52	10, 21, 40, 44, 45, 99
Surgeon	39-41, 61	73, 126
Company commanders	4, 6, 10, 26, 31	7, 13, 21, 45, 56
Leader of ammunition and pioneer platoon	5, 13, 26	10, 31, 45
Munitions officer	4, 23	7, 40
Regimental:		
Motor transport officer	4, 31, 52	7, 56, 99
Munitions officer	4, 23, 24, 51	7, 40, 44, 95

INDEX (Continued)

	<i>Paragraphs</i>	<i>Pages</i>
Supply officer	3, 4, 10, 19, 48, 50	3, 7, 21, 36, 86, 92
Surgeon	39, 46, 60	73, 82, 121
Service company commander	4, 10, 11, 12, 19, 20	7, 21, 26, 30, 36, 37
 <i>Echelons:</i>		
Of motor maintenance	31, app. III	56, 134
Of supply	3	3
 <i>Engineer:</i>		
Fortification material. (See Supply, class IV.)		
Intrenching equipment. (See Supply, class II.)		
Water supply. (See Supply, class I.)		
 <i>Evacuation:</i>		
Of personnel	37, 45	69, 81
Of materiel	32	60
Exploitation and battlefield recovery.....	32	60
Extra ammunition	24, 26	44, 45
Fifth echelon maintenance	31	56
First echelon maintenance	31	56
Flank guards, medical service for.....	39	73
Food. (See Supply, class I.)		
Fortification material. (See Supply, class IV.)		
Fourth echelon maintenance	31	56
Fuel. (See Supply, class III.)		
Gas masks. (See Supply, class II.)		
Gasoline. (See Supply, class III.)		
Grease. (See Supply, class III.)		
Impetus of supply	3	3
Individual rolls	47	83
Inspection of motor vehicles	31	56
Intrenching equipment. (See Supply, class II.)		

INDEX (Continued)

	<i>Paragraphs</i>	<i>Pages</i>
Kitchen and baggage train.....	52	99
Landing operations, ammunition supply....	30	55
Logistical data	1	1
Maintenance:		
During marches and combat.....	31	56
Echelons of	31, app. III	56, 134
Installations	31, 52	56
Motor	31, app. III	56, 134
Of equipment	31, 32	56, 60
Section, transportation platoon	52	99
Train	52	99
Warrant officer	52	99
Mechanic, automobile	31, 52	56, 99
Medical:		
Aid station. (<i>See</i> Aid station.)		
Battalion	45	81
Detachment, organization of	58-63	119
Equipment	62	128
Evacuation	37, 45	69, 81
Mission	36	68
Personnel, duties of	60	121
Service in:		
Attack	41	76
Approach march and assembly areas	40	75
Bivouac	46	82
Camp	46	82
Defense	42	80
Development	41	76
Pursuit	41	76
Rear guards	39	73
Retrograde movements	43	80
Route march	39	73
Train bivouac	44	81
Supply	14, 62	31, 128
Supporting medical echelon	45	81
Train. (<i>See</i> Train.)		

INDEX (Continued)

	<i>Paragraphs</i>	<i>Pages</i>
Military personnel officer	51	95
Motor:		
Maintenance	31, app. III	56, 134
Marches	31	56
Transport officer. (See Regimental or battalion motor transport officer.)		
Vehicle:		
Destruction	34	62
Inspection	31	56
Repair. (See Motor maintenance.)		
Supply. (See Supply, class II.)		
Munitions: (See also Supply, class V.)		
Group	23	40
Officer, regimental	4, 23, 24, 51	7, 40, 44, 95
Warrant officer	51	95
Oil. (See Supply, class III.)		
Organization of:		
Medical detachment	54-62	108
Service company	49-53	90
Orientation officer	51	95
Prescribed supplies	2, 3	1, 3
Procurement of supplies (see also Supply)	3	3
Pursuit, medical service in	41	76
Pyrotechnics. (See Supply, class V.)		
Radios. (See Supply, class I.)		
Rapidly moving situations, ammunition supply	27	52
Ration(s). (See Supply, class I.)		
Rear guards, medical service for.....	39	73
References	1, 25, app. I	1, 44, 130
Regimental:		
Aid station. (See Aid station.)		
Distributing point. (See Supply.)		
Medical detachment. (See Medical detachment.)		

INDEX (Continued)

	<i>Paragraphs</i>	<i>Pages</i>
Motor transport officer	4, 31, 52	7, 56, 99
Munitions officer	4, 23, 24, 51	7, 40, 44, 95
Supply officer	3, 4, 10, 19, 48, 50	3, 7, 21, 36, 86, 92
Surgeon	39, 46, 60	73, 82, 121
Train bivouac	10, 52, 54, 57	21, 99, 108, 110
Release point	2, 10, 33	1, 21, 61
Repair and replacement of equipment.....	33	61
Requirements	2	1
Requisitions	3, 12, 14, 18	3, 30, 31, 36
Retrograde movements:		
Ammunition supply	29	54
Medical service during	43	80
Rolls, individual	47	83
Route march:		
Ammunition supply	24	44
Medical service	39	73
Route of ammunition advance	23	40
S-4. (See Regimental supply officer.)		
Salvage	32	60
Sanitation	60	121
Second echelon motor maintenance	31	56
Security:		
Of supplies	3, 23	3, 40
Of installations	23, 52, 57	40, 99, 110
Service company:		
Commander	4, 10, 11, 12, 19, 20	7, 21, 26, 30, 36, 37
Company headquarters	50	92
Composition of	49	90
Duties of personnel	50-53	92
Operation	54-57	108
Regimental headquarters platoon	51	95
Training	53	107
Transportation platoon	52	99

INDEX (Continued)

	<i>Paragraphs</i>	<i>Pages</i>
Sick call	46	82
Signal supplies. (See Supply, class IV.)		
Special services officer	51	95
Sterilizing of water	11	26
Strength report	8	17
Supply:		
Administrative plans and orders..1, 2, 4, 7, 10, 47, 48		1, 7, 14, 21, 83, 86
Ammunition. (See Supply, class V.)		
Attached elements	3	3
Attack, in	26	45
Chemicals. (See Supply, class V.)		
Class I (rations, water, etc.):		
Definition	7	14
Distribution	9, 10	19, 21
Plan	10, 47	21, 52
Procurement of rations	8	17
Ration:		
Break-down	8, 9, app. II	17, 19, 132
Cycle	8	17
Definition	7	14
Garrison	7	14
Plan	10, 47	21, 52
Preparation	10	21
Procurement of	8	17
Reserve	7, 10	14, 21
Savings	7	14
Supply point	9	19
Water	11	26
Class II (clothing, arms, medical supplies, equipment, etc.)	12-14	30
Class III (gasoline, grease, and oil)	15-17, 47	33, 83
Class IV (engineer fortification material, and signal supplies.)	18-20, 47	36, 83
Class V (ammunition, pyrotechnics, antitank mines, chemicals, etc.):		
Advance march	25	44

INDEX (Continued)

	<i>Paragraphs</i>	<i>Pages</i>
Ammunition:		
Plan	21, 47	38, 83
Supply point	21, 23, 26, 47	38, 40, 45, 83
Trains	24, 52	44, 99
Antitank company	26, 28	45, 52
Approach march	25	44
Army ammunition supply point	22	39
Attack	26	45
Battalion ammunition supply point	26	45
Cannon company	26, 28	45, 52
Defense	28	52
Extra ammunition	24, 26	44, 45
Landing operations	30	55
Procurement of	22, 23	39, 40
Rapidly moving situations	27	52
Regimental ammunition supply point	26	45
Retrograde movements	29	54
Route of ammunition advance	23	40
Route march	24	44
Clothing. (<i>See</i> Supply, class II.)		
Echelons of supply	3	3
Gas mask. (<i>See</i> Supply, class II.)		
Gasoline. (<i>See</i> Supply, class III.)		
Medical supplies	14, 62	31
Mission	3	3
Motor vehicles. (<i>See</i> Supply, class II.)		
Officer. (<i>See</i> Regimental or battalion supply officer).		
Point	3, 9, 21, 23, 26, 47, 50	3, 19, 38, 40, 45, 83, 92
Plans	10, 47	21, 83
Principles of	3	3
Procedure	3	3
Requirements	2	1
Requisition	3, 12, 14	3, 30, 31
Salvage	32	60

INDEX (Continued)

	Paragraphs	Pages
Security of supplies	3, 23	3, 40
Surgeon:		
Battalion	39-41, 61	73, 126
Dental	60	121
Regimental	39, 46, 60	73, 82, 121
Third echelon maintenance	31	56
Traffic control	47	83
Train(s)	24, 52, 60	44, 99, 121
Train bivouac	10, 52, 54, 57	21, 99, 108, 110
Medical service of	44	81
Transportation platoon, service company	52	99
Training:		
Medical detachment	63	129
Service company	53	107
Unit mle	17	35
Vehicles. (See motor vehicles.)		
Warning system	52, 57	99, 110
Water. (See Supply, class I.)		
Weapons:		
Destruction	34	62
Supply. (See Supply, class II.)		